



Brussels, 17.3.2016
COM(2016) 157 final

ANNEXES 1 to 5

Circular economy package

ANNEXES

to the

Proposal for a regulation of the European Parliament and of the Council

laying down rules on the making available on the market of CE marked fertilising products and amending Regulations (EC) No 1069/2009 and (EC) No 1107/2009

{SWD(2016) 64 final}

{SWD(2016) 65 final}

ANNEXES

to the

Proposal for a regulation of the European Parliament and of the Council

laying down rules on the making available on the market of CE marked fertilising products and amending Regulations (EC) No 1069/2009 and (EC) No 1107/2009

ANNEX I
Product Function Categories ('PFC') of CE marked fertilising products

PART I
DESIGNATION OF PRODUCT FUNCTION CATEGORIES

1. Fertiliser
 - A. Organic fertiliser
 - I. Solid organic fertiliser
 - II. Liquid organic fertiliser
 - B. Organo-mineral fertiliser
 - I. Solid organo-mineral fertiliser
 - II. Liquid organo-mineral fertiliser
 - C. Inorganic fertiliser
 - I. Inorganic macronutrient fertiliser
 - a) Solid inorganic macronutrient fertiliser
 - i) Straight solid inorganic macronutrient fertiliser
 - A) Straight solid inorganic macronutrient ammonium nitrate fertiliser of high nitrogen content
 - ii) Compound solid inorganic macronutrient fertiliser
 - A) Compound solid inorganic macronutrient ammonium nitrate fertiliser of high nitrogen content
 - b) Liquid inorganic macronutrient fertiliser
 - i) Straight liquid inorganic macronutrient fertiliser
 - ii) Compound liquid inorganic macronutrient fertiliser
 - II. Inorganic micronutrient fertiliser
 - a) Straight inorganic micronutrient fertiliser
 - b) Compound inorganic micronutrient fertiliser
2. Liming material
3. Soil improver
 - A. Organic soil improver
 - B. Inorganic soil improver
4. Growing medium
5. Agronomic additive
 - A. Inhibitor
 - I. Nitrification inhibitor
 - II. Urease inhibitor
 - B. Chelating agent
 - C. Complexing agent
6. Plant biostimulant
 - A. Microbial plant biostimulant
 - B. Non-microbial plant biostimulant
 - I. Organic non-microbial plant biostimulant
 - II. Inorganic non-microbial plant biostimulant
7. Fertilising product blend

PART II

REQUIREMENTS RELATED TO PRODUCT FUNCTION CATEGORIES

1. This Part sets out the requirements related to the Product Function Categories ('PFC') to which CE marked fertilising products shall belong.
2. The requirements laid down in this Annex for a given PFC apply to CE marked fertilising products in all subcategories of that PFC.
3. Where compliance with a given requirement (such as absence of a given contaminant) follows certainly and uncontestably from the nature or manufacturing process of a CE marked fertilising product, that compliance can be presumed in the conformity assessment without verification (such as testing), at the responsibility of the manufacturer.
4. Where the CE marked fertilising product contains a substance for which maximum residue limits for food and feed have been established in accordance with
 - (a) Council Regulation (EEC) No 315/93¹,
 - (b) Regulation (EC) No 396/2005 of the European Parliament and of the Council²,
 - (c) Regulation (EC) No 470/2009 of the European Parliament and of the Council³
or
 - (d) Directive 2002/32/EC of the European Parliament and of the Council⁴,the use of the CE marked fertilising product as specified in the use instructions must not lead to the exceedance of those limits in food or feed.

PFC 1: FERTILISER

A fertiliser shall be a CE marked fertilising product aimed at providing nutrients to plants.

PFC 1(A): Organic fertiliser

1. An organic fertiliser shall contain
 - carbon (C) and
 - nutrientsof solely biological origin, excluding material which is fossilized or embedded in geological formations.

¹ Council Regulation (EEC) No 315/93 of 8 February 1993 laying down Community procedures for contaminants in food (OJ L 37, 13.2.1993, p. 1).

² Regulation (EC) No 396/2005 of the European Parliament and of the Council of 23 February 2005 on maximum residue levels of pesticides in or on food and feed of plant and animal origin and amending Council Directive 91/414/EEC (OJ L 70, 16.3.2005, p. 1).

³ Regulation (EC) No 470/2009 of the European Parliament and of the Council of 6 May 2009 laying down Community procedures for the establishment of residue limits of pharmacologically active substances in foodstuffs of animal origin, repealing Council Regulation (EEC) No 2377/90 and amending Directive 2001/82/EC of the European Parliament and of the Council and Regulation (EC) No 726/2004 of the European Parliament and of the Council (OJ L 152, 16.6.2009, p. 11).

⁴ Directive 2002/32/EC of the European Parliament and of the Council of 7 May 2002 on undesirable substances in animal feed (OJ L 140, 30.5.2002, p. 10).

2. Contaminants must not be present in the CE marked fertilising product by more than the following quantities:
 - Cadmium (Cd) 1,5 mg/kg dry matter,
 - Hexavalent chromium (Cr VI) 2 mg/kg dry matter,
 - Mercury (Hg) 1 mg/kg dry matter,
 - Nickel (Ni) 50 mg/kg dry matter,
 - Lead (Pb) 120 mg/kg dry matter, and
 - Biuret (C₂H₅N₃O₂) 12 g/kg dry matter.
3. *Salmonella spp.* shall be absent in a 25 g sample of the CE marked fertilising product.
4. None of the two following types of bacteria shall be present in the CE marked fertilising product in a concentration of more than 1000 CFU/g fresh mass:
 - (a) *Escherichia coli*, or
 - (b) Enterococcaceae.

This shall be demonstrated by measuring the presence of at least one of those two types of bacteria.

PFC 1(A)(I): Solid organic fertiliser

1. A solid organic fertiliser shall contain 40% or more dry matter by mass.
2. The CE marked fertilising product shall contain at least one of the following declared nutrients in the minimum quantities stated:
 - 2,5% by mass of total nitrogen (N),
 - 2% by mass of total phosphorus pentoxide (P₂O₅), or
 - 2% by mass of total potassium oxide (K₂O).
3. Organic carbon (C) shall be present in the CE marked fertilising product by at least 15% by mass.

PFC 1(A)(II): Liquid organic fertiliser

1. A liquid organic fertiliser shall contain less than 40% dry matter.
2. The CE marked fertilising product shall contain at least one of the following declared nutrients in the minimum quantities stated:
 - 2% by mass of total nitrogen (N),
 - 1% by mass of total phosphorus pentoxide (P₂O₅), or
 - 2% by mass of total potassium oxide (K₂O).
3. Organic carbon (C) shall be present in the CE marked fertilising product by at least 5% by mass.

PFC 1(B): Organo-mineral fertiliser

1. An organo-mineral fertiliser shall be a co-formulation of
 - one or more inorganic fertilisers, as specified in PFC 1(C) below, and

- a material containing
 - organic carbon (C) and
 - nutrients
 of solely biological origin, excluding material which is fossilized or embedded in geological formations.
2. Where one or more of the inorganic fertilisers in the co-formulation is a straight or compound solid inorganic macronutrient ammonium nitrate fertiliser of high nitrogen content, as specified in PFC 1(C)(I)(a)(i-ii)(A), the CE marked fertilising product shall not contain 15,75 % or more by mass of nitrogen (N) as a result of ammonium nitrate (NH₄NO₃).
 3. Contaminants must not be present in the CE marked fertilising product by more than the following quantities:
 - (a) Cadmium (Cd)
 - (1) Where the CE marked fertilising product has a total phosphorus (P) content of less than 5 % phosphorus pentoxide (P₂O₅)-equivalent by mass: 3 mg/kg dry matter, or
 - (2) Where the CE marked fertilising product has a total phosphorus (P) content of 5 % phosphorus pentoxide (P₂O₅)-equivalent or more by mass ('phosphate fertiliser'):
 - As of [Publications office, please insert the date of application of this Regulation]: 60 mg/kg phosphorus pentoxide (P₂O₅),
 - As of [Publications office, please insert the date occurring three years after the date of application of this Regulation]: 40 mg/kg phosphorus pentoxide (P₂O₅), and
 - As of [Publications office, please insert the date occurring twelve years after the date of application of this Regulation]: 20 mg/kg phosphorus pentoxide (P₂O₅),
 - (b) Hexavalent chromium (Cr VI) 2 mg/kg dry matter,
 - (c) Mercury (Hg) 1 mg/kg dry matter,
 - (d) Nickel (Ni) 50 mg/kg dry matter, and
 - (e) Lead (Pb) 120 mg/kg dry matter.
 4. *Salmonella spp.* shall be absent in a 25 g sample of the CE marked fertilising product.
 5. None of the two following types of bacteria shall be present in the CE marked fertilising product in a concentration of more than 1000 CFU/g fresh mass:
 - (a) *Escherichia coli*, or
 - (b) Enterococcaceae.

This shall be demonstrated by measuring the presence of at least one of those two types of bacteria.

PFC 1(B)(I): Solid organo-mineral fertiliser

1. A solid organo-mineral fertiliser shall contain 60% or more dry matter by mass.

2. The CE marked fertilising product shall contain at least one of the following declared nutrients in the minimum quantities stated:
 - 2,5 % by mass of total nitrogen (N), out of which 1 % by mass of the CE marked fertilising product shall be organic nitrogen (N), or
 - 2 % by mass of total phosphorus pentoxide (P₂O₅), or
 - 2 % by mass of total potassium oxide (K₂O).
3. Organic carbon (C) shall be present in the CE marked fertilising product by at least 7.5 % by mass.
4. In the CE marked fertilising product, each unit shall contain the organic matter and the nutrients in their declared content.

PFC 1(B)(II): Liquid organo-mineral fertiliser

1. A liquid organo-mineral fertiliser shall contain less than 60 % dry matter by mass.
2. The CE marked fertilising product shall contain at least one of the following declared nutrients in the minimum quantities stated:
 - 2 % by mass of total nitrogen (N), out of which 0,5 % by mass of the CE marked fertilising product shall be organic nitrogen (N), or
 - 2 % by mass of total phosphorus pentoxide (P₂O₅), or
 - 2 % by mass of total potassium oxide (K₂O).
3. Organic carbon (C) shall be present in the CE marked fertilising product by at least 3 % by mass.

PFC 1(C): Inorganic fertiliser

An inorganic fertiliser shall be a fertiliser other than an organic or organo-mineral fertiliser.

PFC 1(C)(I): Inorganic macronutrient fertiliser

1. An inorganic macronutrient fertiliser shall be aimed at providing plants with one or more of the following macronutrients: nitrogen (N), phosphorus (P), potassium (K), magnesium (Mg), calcium (Ca), sulphur (S) or sodium (Na).
2. Contaminants must not be present in the CE marked fertilising product by more than the following quantities:
 - (a) Cadmium (Cd)
 - (1) Where the CE marked fertilising product has a total phosphorus (P) content of less than 5 % phosphorus pentoxide (P₂O₅)-equivalent by mass: 3 mg/kg dry matter, or
 - (2) Where the CE marked fertilising product has a total phosphorus (P) content of 5 % phosphorus pentoxide (P₂O₅)-equivalent or more by mass ('phosphate fertiliser'):
 - As of [Publications office, please insert the date of application of this Regulation]: 60 mg/kg phosphorus pentoxide (P₂O₅),

- As of [Publications office, please insert the date occurring three years after the date of application of this Regulation]: 40 mg/kg phosphorus pentoxide (P₂O₅), and
 - As of [Publications office, please insert the date occurring twelve years after the date of application of this Regulation]: 20 mg/kg phosphorus pentoxide (P₂O₅),
- (b) Hexavalent chromium (Cr VI) 2 mg/kg dry matter,
- (c) Mercury (Hg) 2 mg/kg dry matter,
- (d) Nickel (Ni) 120 mg/kg dry matter,
- (e) Lead (Pb) 150 mg/kg dry matter,
- (f) Arsenic (As) 60 mg/kg dry matter,
- (g) Biuret (C₂H₅N₃O₂) 12 g/kg dry matter, and
- (h) Perchlorate (ClO₄⁻) 50 mg/kg dry matter.

PFC 1(C)(I)(a): Solid inorganic macronutrient fertiliser

A solid inorganic fertiliser shall be an inorganic macronutrient fertiliser, which is neither in suspension nor in solution within the meaning of PFC 1(C)(I)(b) in this Annex.

PFC 1(C)(I)(a)(i): Straight solid inorganic macronutrient fertiliser

1. A straight solid inorganic macronutrient fertiliser shall have a declared content of not more than one nutrient.
2. The CE marked fertilising product shall contain one of the following declared nutrients in the minimum quantity stated:
 - 10% by mass of total nitrogen (N),
 - 12% by mass of total phosphorus pentoxide (P₂O₅),
 - 6% by mass of total potassium oxide (K₂O),
 - 5% by mass of total magnesium oxide (MgO),
 - 12% by mass of total calcium oxide (CaO),
 - 10% by mass of total sulphur trioxide (SO₃), or
 - 1% by mass of total sodium oxide (Na₂O).

PFC 1(C)(I)(a)(ii): Compound solid inorganic macronutrient fertiliser

1. A compound solid inorganic macronutrient fertiliser shall have a declared content of more than one nutrient.
2. The CE marked fertilising product shall contain more than one of the following declared nutrients in the minimum quantities stated:
 - 3% by mass of total nitrogen (N),
 - 3% by mass of total phosphorus pentoxide (P₂O₅),
 - 3% by mass of total potassium oxide (K₂O),
 - 1,5% by mass of total magnesium oxide (MgO),

- 1,5% by mass of total calcium oxide (CaO),
- 1,5% by mass of total sulphur trioxide (SO₃), or
- 1% by mass of total sodium oxide (Na₂O).

PFC 1(C)(I)(a)(i-ii)(A): Straight or compound solid inorganic macronutrient ammonium nitrate fertiliser of high nitrogen content

1. A straight or compound solid inorganic macronutrient ammonium nitrate fertiliser of high nitrogen content shall be ammonium nitrate (NH₄NO₃)-based and contain 28 % or more by mass of nitrogen (N) as a result of ammonium nitrate (NH₄NO₃).
2. Any matter other than ammonium nitrate (NH₄NO₃) shall be inert towards ammonium nitrate (NH₄NO₃).
3. The CE marked fertilising product shall be made available to the end-user only in packaged form. The package shall be closed in such a way or by such a device that, when it is opened, the fastening, the fastening seal or the package itself is irreparably damaged. Valve sacks may be used.
4. The oil retention of the CE marked fertilising product, following two thermal cycles as described under Heading 4.1 in Module A1 in Annex IV, must not exceed 4 % by mass.
5. The detonation resistance of the CE marked fertilising product shall be such, that
 - following five thermal cycles as described under Heading 4.2 in Module A1 in Annex IV,
 - in two detonation resistance tests as described under Heading 4.3 in module A1 in Annex IV,
 one or more of the supporting lead cylinders is crushed by less than 5 %.
6. The percentage by mass of combustible material measured as carbon (C) must not exceed
 - 0,2 % for CE marked fertilising products having a nitrogen (N) content of at least 31,5 % by mass, and
 - 0,4 % for CE marked fertilising products having a nitrogen (N) content of at least 28 % but less than 31,5 % by mass.
7. A solution of 10 g of the CE marked fertilising product in 100 ml of water must have a pH of at least 4,5.
8. Not more than 5 % by mass of the CE marked fertilising product shall pass through a 1 mm mesh sieve, and not more than 3 % by mass shall pass through a 0,5 mm mesh sieve.
9. The copper (Cu) content shall not be higher than 10 mg/kg, and the chlorine (Cl) content shall not be higher than 200 mg/kg.

PFC 1(C)(I)(b): Liquid inorganic macronutrient fertiliser

A liquid inorganic macronutrient fertiliser shall be an inorganic macronutrient fertiliser in suspension or in solution, where

- a suspension means a two-phase dispersion in which solid particles are maintained in suspension in the liquid phase, and

- a solution means a liquid that is free of solid particles.

PFC 1(C)(I)(b)(i): Straight liquid inorganic macronutrient fertiliser

1. A straight liquid inorganic macronutrient fertiliser shall have a declared content of not more than one nutrient.
2. The CE marked fertilising product shall contain one of the following declared nutrients in the minimum quantity stated:
 - 5% by mass of total nitrogen (N),
 - 5% by mass of total phosphorus pentoxide (P₂O₅),
 - 3% by mass of total potassium oxide (K₂O),
 - 2% by mass of total magnesium oxide (MgO),
 - 6% by mass of total calcium oxide (CaO),
 - 5% by mass of total sulphur trioxide (SO₃), or
 - 1% by mass of total sodium oxide (Na₂O).

PFC 1(C)(I)(b)(ii): Compound liquid inorganic macronutrient fertiliser

1. A compound liquid inorganic macronutrient fertiliser shall have a declared content of more than one nutrient.
2. The CE marked fertilising product shall contain more than one of the following declared nutrients in the minimum quantities stated:
 - 1,5% by mass of total nitrogen (N),
 - 1,5% by mass of total phosphorus pentoxide (P₂O₅),
 - 1,5% by mass of total potassium oxide (K₂O),
 - 0,75% by mass of total magnesium oxide (MgO),
 - 0,75% by mass of total calcium oxide (CaO),
 - 0,75% by mass of total sulphur trioxide (SO₃), or
 - 0,5% by mass of total sodium oxide (Na₂O).

PFC 1(C)(II): Inorganic micronutrient fertiliser

1. An inorganic micronutrient fertiliser shall be an inorganic fertiliser other than a macronutrient fertiliser aimed at providing one or more of the following nutrients: boron (B), cobalt (Co), copper (Cu), iron (Fe), manganese (Mn), molybdenum (Mo) or zinc (Zn).
2. Micronutrient fertilisers shall be made available to the end-user only in packaged form.

3. Contaminants must not be present in the CE marked fertilising product by more than the following quantities:

Contaminant	Maximum concentration by mass, in relation to the total micronutrient content (mg/kg of total boron (B), cobalt (Co), copper (Cu), iron (Fe), manganese (Mn), molybdenum (Mo), and zinc (Zn))
Arsenic (As)	1000
Cadmium (Cd)	200
Lead (Pb)	600
Mercury (Hg)	100
Nickel (Ni)	2000

PFC 1(C)(II)(a): Straight inorganic micronutrient fertiliser

1. A straight inorganic micronutrient fertiliser shall have a declared content of not more than one nutrient.
2. The CE marked fertilising product shall comply with the one of the typologies, descriptions and corresponding minimum nutrient content requirements in the table below:

Typology	Description	Minimum nutrient content
Micronutrient salt fertiliser	A chemically obtained solid micronutrient fertiliser containing a mineral ion salt, oxide or hydroxide as its essential ingredient	10% by mass of the CE marked fertilising product shall consist of water-soluble micronutrient
Micronutrient-based fertiliser	A micronutrient fertiliser combining a micronutrient salt fertiliser with one or more other micronutrient salt fertilisers and/or with a single micronutrient chelate	5% by mass of the CE marked fertilising product shall consist of micronutrient
Micronutrient solution fertiliser	An aqueous solution of different forms of a micronutrient fertiliser	2% by mass of the CE marked fertilising product shall consist of water-soluble micronutrient
Micronutrient suspension fertiliser	A product obtained by suspending different forms of a micronutrient fertiliser	2% by mass of the CE marked fertilising product shall consist of micronutrient

Micronutrient chelate fertiliser	A water-soluble product in which the declared micronutrient is chemically combined with chelating agent(s) fulfilling the requirements of PFC 5(B)	<ul style="list-style-type: none"> • 5% by mass of the CE marked fertilising product shall consist of water-soluble micronutrient, and • at least 80% of the water-soluble micronutrient shall be chelated by a chelating agent fulfilling the requirements of PFC 5(B)
Micronutrient complex fertiliser	A water-soluble product in which the declared micronutrient is chemically combined with complexing agent(s) fulfilling the requirements of PFC 5(C)	<ul style="list-style-type: none"> • 5% by mass of the CE marked fertilising product shall consist of water-soluble micronutrient, and • at least 80% of the water-soluble micronutrient shall be complexed by a complexing agent fulfilling the requirements of PFC 5(C)

PFC 1(C)(II)(b): Compound inorganic micronutrient fertiliser

1. A compound inorganic micronutrient fertiliser shall have a declared content of more than one micronutrient.
2. The CE marked fertilising product shall contain declared nutrients in at least one of the following quantities:
 - 2% by mass for fertilisers in suspension or solution ('liquid compound inorganic micronutrient fertilisers'), where
 - a suspension means a two-phase dispersion in which solid particles are maintained in suspension in the liquid phase, and
 - a solution means a liquid that is free of solid particles, and
 - 5% by mass for other fertilisers ('solid compound inorganic micronutrient fertilisers').

PFC 2: LIMING MATERIAL

1. A liming material shall be a CE marked fertilising product aimed at correcting soil acidity, and containing oxides, hydroxides, carbonates or silicates of the nutrients calcium (Ca) or magnesium (Mg).

2. Contaminants must not be present in the CE marked fertilising product by more than the following quantities:
 - Cadmium (Cd) 3 mg/kg dry matter,
 - Hexavalent chromium (Cr VI) 2 mg/kg dry matter,
 - Mercury (Hg) 2 mg/kg dry matter,
 - Nickel (Ni) 90 mg/kg dry matter,
 - Lead (Pb) 200 mg/kg dry matter, and
 - Arsenic (As) 120 mg/kg dry matter.
3. The following parameters determined on dry matter shall be met:
 - Minimum neutralising value: 15 (equivalent CaO) or 9 (equivalent HO⁻), and
 - Minimum reactivity: 10% or 50% after 6 months (incubation test).

PFC 3: SOIL IMPROVER

A soil improver shall be a CE marked fertilising product aimed at being added to the soil for the purpose of maintaining, improving or protecting the physical or chemical properties, the structure or the biological activity of soil.

PFC 3(A): Organic soil improver

1. An organic soil improver shall consist exclusively of material of solely biological origin, excluding material which is fossilized or embedded in geological formations.
2. Contaminants must not be present in the CE marked fertilising product by more than the following quantities:
 - Cadmium (Cd) 3 mg/kg dry matter,
 - Hexavalent chromium (Cr VI) 2 mg/kg dry matter,
 - Mercury (Hg) 1 mg/kg dry matter,
 - Nickel (Ni) 50 mg/kg dry matter, and
 - Lead (Pb) 120 mg/kg dry matter.
3. When the CE marked fertilising product contains an animal by-product as defined in Regulation (EC) No 1069/2009
 - (a) *Salmonella spp.* shall be absent in a 25 g sample of the CE marked fertilising product.
 - (b) None of the two following types of bacteria shall be present in the CE marked fertilising product in a concentration of more than 1000 CFU/g fresh mass:
 - *Escherichia coli*, or
 - Enterococcaceae.

This shall be demonstrated by measuring the presence of at least one of those two types of bacteria.
4. The CE marked fertilising product shall contain 40% or more dry matter.

5. Organic carbon (C) shall be present in the CE marked fertilising product by at least 7.5% by mass.

PFC 3(B): Inorganic soil improver

1. An inorganic soil improver shall be a soil improver other than an organic soil improver.
2. Contaminants must not be present in the CE marked fertilising product by more than the following quantities:
 - Cadmium (Cd) 1,5 mg/kg dry matter,
 - Hexavalent chromium (Cr VI) 2 mg/kg dry matter,
 - Mercury (Hg) 1 mg/kg dry matter,
 - Nickel (Ni) 100 mg/kg dry matter, and
 - Lead (Pb) 150 mg/kg dry matter.

PFC 4: GROWING MEDIUM

1. A growing medium shall be a material other than soil intended for use as a substrate for root development.
2. Contaminants must not be present in the CE marked fertilising product by more than the following quantities:
 - Cadmium (Cd) 3 mg/kg dry matter,
 - Hexavalent chromium (Cr VI) 2 mg/kg dry matter,
 - Mercury (Hg) 1 mg/kg dry matter,
 - Nickel (Ni) 100 mg/kg dry matter, and
 - Lead (Pb) 150 mg/kg dry matter.
3. *Salmonella spp.* shall be absent in a 25 g sample of the CE marked fertilising product.
4. None of the two following types of bacteria shall be present in the CE marked fertilising product in a concentration of more than 1000 CFU/g fresh mass:
 - (a) *Escherichia coli*, or
 - (b) Enterococcaceae.

This shall be demonstrated by measuring the presence of at least one of those two types of bacteria.

PFC 5: AGRONOMIC ADDITIVE

An agronomic additive shall be a CE marked fertilising product intended to be added to a product providing plants with nutrient, with the intention to improve that product's nutrient release patterns.

PFC 5(A): Inhibitor

1. An inhibitor shall be a substance or a mixture which delays or stops the activity of specific groups of micro-organisms or enzymes.

2. Each substance shall have been registered pursuant to Regulation (EC) No 1907/2006,⁵ in a dossier containing
 - (a) the information provided for by Annex VI, VII and VIII of Regulation (EC) No 1907/2006, and
 - (b) a chemical safety report pursuant to Article 14 of Regulation (EC) No 1907/2006 covering the use as fertilising product,unless explicitly covered by one of the registration obligation exemptions provided for by Annex IV to that Regulation or by points 6, 7, 8, or 9 of Annex V to that Regulation.

PFC 5(A)(I): Nitrification inhibitor

1. A nitrification inhibitor shall inhibit the biological oxidation of ammoniacal nitrogen ($\text{NH}_3\text{-N}$) to nitrite nitrogen (NO_2^-), thus slowing the formation of nitrate nitrogen (NO_3^-).
2. A soil-incubation test measuring the ammoniacal nitrogen ($\text{NH}_3\text{-N}$) oxidation rate by
 - ammoniacal nitrogen ($\text{NH}_3\text{-N}$) disappearance, or
 - the sum of nitrite nitrogen (NO_2^-) and nitrate nitrogen (NO_3^-) production with respect to time

in a soil sample where the nitrification inhibitor has been added shall show a statistical difference in ammoniacal nitrogen ($\text{NH}_3\text{-N}$) oxidation rate when compared to a control sample where the nitrification inhibitor has not been added.

PFC 5(A)(II): Urease inhibitor

1. An urease inhibitor shall inhibit hydrolytic action on urea ($\text{CH}_4\text{N}_2\text{O}$) by the urease enzyme, primarily targeted to reduce ammonia volatilisation.
2. An in-vitro measuring of the rate of hydrolysis of urea ($\text{CH}_4\text{N}_2\text{O}$) with respect to time in a soil sample where the urease inhibitor has been added shall show a statistical difference in hydrolysis rate when compared to a control sample where the urease inhibitor has not been added.

PFC 5(B): Chelating agent

1. A chelating agent shall be an organic substance intended to enhance nutrients' long-term availability to plants consisting in a molecule which
 - has two or more sites that donate electron pairs to a central transition metal cation (zinc (Zn), copper (Cu), iron (Fe), manganese (Mn), magnesium (Mg), calcium (Ca) or cobalt (Co)), and which
 - is large enough to form a five- or six- membered ring structure.

⁵ In the case of an additive recovered in the European Union, this condition is fulfilled if the additive is the same, within the meaning of Article 2(7)(d)(i) of Regulation (EC) No 1907/2006, as a substance registered in a dossier containing the information here indicated, and if information is available to the fertilising product manufacturer within the meaning of Article 2(7)(d)(ii) of Regulation (EC) No 1907/2006.

2. The substance shall have been registered pursuant to Regulation (EC) No 1907/2006,⁶ in a dossier containing
 - (a) the information provided for by Annex VI, VII and VIII of Regulation (EC) No 1907/2006, and
 - (b) a chemical safety report pursuant to Article 14 of Regulation (EC) No 1907/2006 covering the use as fertilising product,unless explicitly covered by one of the registration obligation exemptions provided for by Annex IV to that Regulation or by points 6, 7, 8, or 9 of Annex V to that Regulation.
3. After 3 days in standard Hoagland solution at pH 7 and 8, the CE marked fertilising product shall remain stable.

PFC 5(C): Complexing agent

1. A complexing agent shall be an organic substance intended to enhance nutrients' long-term availability to plants, which can form a flat or steric structure with one di or three valent transition metal cation.
2. The substance shall have been registered pursuant to Regulation (EC) No 1907/2006,⁷ in a dossier containing
 - (a) the information provided for by Annex VI, VII and VIII of Regulation (EC) No 1907/2006, and
 - (b) a chemical safety report pursuant to Article 14 of Regulation (EC) No 1907/2006 covering the use as fertilising product,unless explicitly covered by one of the registration obligation exemptions provided for by Annex IV to that Regulation or by points 6, 7, 8, or 9 of Annex V to that Regulation.
3. After 1 day in water solution at pH 6 and 7, the CE marked fertilising product shall remain stable.

PFC 6: PLANT BIOSTIMULANT

1. A plant biostimulant shall be a CE marked fertilising product stimulating plant nutrition processes independently of the product's nutrient content with the sole aim of improving one or more of the following characteristics of the plant:
 - (a) nutrient use efficiency,
 - (b) tolerance to abiotic stress, or
 - (c) crop quality traits.

⁶ In the case of an additive recovered in the European Union, this condition is fulfilled if the additive is the same, within the meaning of Article 2(7)(d)(i) of Regulation (EC) No 1907/2006, as a substance registered in a dossier containing the information here indicated, and if information is available to the fertilising product manufacturer within the meaning of Article 2(7)(d)(ii) of Regulation (EC) No 1907/2006.

⁷ In the case of an additive recovered in the European Union, this condition is fulfilled if the additive is the same, within the meaning of Article 2(7)(d)(i) of Regulation (EC) No 1907/2006, as a substance registered in a dossier containing the information here indicated, and if information is available to the fertilising product manufacturer within the meaning of Article 2(7)(d)(ii) of Regulation (EC) No 1907/2006.

2. Contaminants must not be present in the CE marked fertilising product by more than the following quantities:
 - Cadmium (Cd) 3 mg/kg dry matter,
 - Hexavalent chromium (Cr VI) 2 mg/kg dry matter, and
 - Lead (Pb) 120 mg/kg dry matter.
3. The plant biostimulant shall have the effects that are claimed on the label for the crops specified thereon.

PFC 6(A): Microbial plant biostimulant

1. A microbial plant biostimulant shall consist solely of a micro-organism or a consortium of micro-organisms referred to in Component Material Category 7 of Annex II.
2. Contaminants must not be present in the CE marked fertilising product by more than the following quantities:
 - Mercury (Hg) 1 mg/kg dry matter, and
 - Nickel (Ni) 50 mg/kg dry matter.
3. *Salmonella spp.* shall be absent in a 25 g or 25 ml sample of the CE marked fertilising product.
4. *Escherichia coli* shall be absent in a 1 g or 1 ml sample of the CE marked fertilising product.
5. Enterococcaceae must not be present in the CE marked fertilising product by more than 10 CFU/g fresh mass.
6. *Listeria monocytogenes* shall be absent in a 25 g or 25 ml sample of the CE marked fertilising product.
7. *Vibrio spp* shall be absent in a 25 g or 25 ml sample of the CE marked fertilising product.
8. *Shigella spp* shall be absent in a 25 g or 25 ml sample of the CE marked fertilising product.
9. *Staphylococcus aureus* shall be absent in a 1 g or 1 ml sample of the CE marked fertilising product.
10. Aerobic plate count shall not exceed 10^5 CFU/g or ml sample of the CE marked fertilising product, unless the microbial biostimulant is an aerobic bacterium.
11. Yeast and mould count shall not exceed 1000 CFU/g or ml sample of the CE marked fertilising product, unless the microbial biostimulant is a fungus.
12. When the microbial plant biostimulant consists of a suspension or a solution, where
 - a suspension means a two-phase dispersion in which solid particles are maintained in suspension in the liquid phase, and
 - a solution means a liquid that is free of solid particles,the plant biostimulant shall have a pH superior or equal to 4.
13. The shelf-life of the microbial plant biostimulant shall be at least 6 months under the storage conditions specified on the label.

PFC 6(B): Non-microbial plant biostimulant

A non-microbial plant biostimulant shall be a plant biostimulant other than a microbial plant biostimulant.

PFC 6(B)(I): Organic non-microbial plant biostimulant

1. An organic non-microbial plant biostimulant shall consist of a substance or a mixture containing carbon (C) of solely animal or plant origin.
2. Contaminants must not be present in the CE marked fertilising product by more than the following quantities:
 - Mercury (Hg) 1 mg/kg dry matter, and
 - Nickel (Ni) 50 mg/kg dry matter.
3. *Salmonella spp.* shall be absent in a 25 g sample of the CE marked fertilising product.
4. None of the two following types of bacteria shall be present in the CE marked fertilising product by more than 1000 CFU/g fresh mass:
 - (a) *Escherichia coli*, or
 - (b) Enterococcaceae.

This shall be demonstrated by measuring the presence of at least one of those two types of bacteria.

PFC 6(B)(II): Inorganic non-microbial plant biostimulant

1. An inorganic non-microbial plant biostimulant shall be a non-microbial plant biostimulant other than an organic non-microbial plant biostimulant.
2. Contaminants must not be present in the CE marked fertilising product by more than the following quantities:
 - Mercury (Hg) 2 mg/kg dry matter,
 - Nickel (Ni) 120 mg/kg dry matter, and
 - Arsenic (As) 60 mg/kg dry matter.

PFC 7: FERTILISING PRODUCT BLEND

1. A fertilising product blend shall be a CE marked fertilising product composed of two or more CE marked fertilising products of category 1-6.
2. The compliance with the requirements of this Regulation of each component fertilising product in the blend shall have been demonstrated in accordance with the conformity assessment procedure applicable to that component fertilising product.
3. The blending shall not change the nature of each component fertilising product
 - in a manner having an adverse effect on human, animal or plant health, on safety, or on the environment, under reasonably foreseeable conditions of storage or use of the CE marked fertilising product blend, or
 - in any other significant manner.
4. The manufacturer of the blend shall assess the conformity of the blend with the requirements set out in paragraphs 1-3 above, ensure the blend's compliance with the

labelling requirements laid down in Annex III, and assume responsibility pursuant to Article 15(4) of this Regulation for the compliance of the blend with the requirements of this Regulation by

- drawing up an EU declaration of conformity for the CE marked fertilising product blend in accordance with Article 6(2) of this Regulation, and
- being in possession of the EU declaration of conformity of each of the component fertilising products.

5. Economic operators making CE marked fertilising product blends available on the market shall respect the following provisions of this Regulation with regard to the EU declaration of conformity of each component fertilising product as well as of the blend:

- Article 6(3) (manufacturers' obligation to keep the EU declaration of conformity);
- Article 7(2)(a) (authorised representatives' obligation to keep the EU declaration of conformity);
- Article 8(2) (importers' obligation to ensure that the CE marked fertilising product is accompanied by the EU declaration of conformity);
- Article 8(8) (importers' obligation to keep a copy of the EU declaration of conformity at the disposal of the market surveillance authorities); and
- Article 9(2) (distributors' obligation to verify that the CE marked fertilising product is accompanied by the EU declaration of conformity).

ANNEX II Component Material Categories

A CE marked fertilising product shall consist solely of component materials complying with the requirements for one or more of the Component Material Categories ('CMC') listed below.

The component materials, or the input materials used to produce them, shall not contain one of the substances for which maximum limit values are indicated in Annex I of this Regulation in such quantities as to jeopardise the CE marked fertilising product's compliance with one of the applicable requirements of that Annex.

PART I **OVERVIEW OF COMPONENT MATERIAL CATEGORIES**

CMC 1: Virgin material substances and mixtures

CMC 2: Non-processed or mechanically processed plants, plant parts or plant extracts

CMC 3: Compost

CMC 4: Energy crop digestate

CMC 5: Other digestate than energy crop digestate

CMC 6: Food industry by-products

CMC 7: Micro-organisms

CMC 8: Agronomic additives

CMC 9: Nutrient polymers

CMC 10: Other polymers than nutrient polymers

CMC 11: Certain animal by-products

PART II **REQUIREMENTS RELATED TO COMPONENT MATERIAL CATEGORIES**

This Part defines the component materials of which CE marked fertilising products shall solely consist.

CMC 1: VIRGIN MATERIAL SUBSTANCES AND MIXTURES

1. A CE marked fertilising product may contain substances and mixtures, other than⁸
 - (a) waste within the meaning of Directive 2008/98/EC,
 - (b) by-products within the meaning of Directive 2008/98/EC,
 - (c) materials formerly having constituted one of the materials mentioned in one of points a-b,
 - (d) animal by-products within the meaning of Regulation (EC) No 1069/2009,
 - (e) polymers, or

⁸ The exclusion of a material from CMC 1 does not prevent it from being an eligible component material by virtue of another CMC stipulating different requirements. See, for instance, CMC 11 on animal by-products, CMCs 9 and 10 on polymers, and CMC 8 on agronomic additives.

- (f) substances or mixtures intended to improve the nutrient release patterns of the CE marked fertilising product into which they are incorporated.
2. All the substances incorporated into the CE marked fertilising product, in their own or in a mixture, shall have been registered pursuant to Regulation (EC) No 1907/2006, in a dossier containing
- (a) the information provided for by Annex VI, VII and VIII of Regulation (EC) No 1907/2006, and
- (b) a chemical safety report pursuant to Article 14 of Regulation (EC) No 1907/2006 covering the use as fertilising product,
- unless explicitly covered by one of the registration obligation exemptions provided for by Annex IV to that Regulation or by points 6, 7, 8, or 9 of Annex V to that Regulation.

CMC 2: NON-PROCESSED OR MECHANICALLY PROCESSED PLANTS, PLANT PARTS OR PLANT EXTRACTS

1. A CE marked fertilising product may contain plants, plant parts or plant extracts having undergone no other processing than cutting, grinding, centrifugation, pressing, drying, freeze-drying or extraction with water.
2. For the purpose of paragraph 1, plants are understood to include algae and exclude blue-green algae.

CMC 3: COMPOST

1. A CE marked fertilising product may contain compost obtained through aerobic composting of exclusively one or more of the following input materials:
- (a) Bio-waste within the meaning of Directive 2008/98/EC resulting from separate bio-waste collection at source;
- (b) Animal by-products of categories 2 and 3 according to Regulation (EC) No 1069/2009;
- (c) Living or dead organisms or parts thereof, which are unprocessed or processed only by manual, mechanical or gravitational means, by dissolution in water, by flotation, by extraction with water, by steam distillation or by heating solely to remove water, or which are extracted from air by any means, except
- the organic fraction of mixed municipal household waste separated through mechanical, physicochemical, biological and/or manual treatment,
 - sewage sludge, industrial sludge or dredging sludge, and
 - animal by-products of category 1 according to Regulation (EC) No 1069/2009;

- (d) Composting additives which are necessary to improve the process performance or the environmental performance of the composting process provided that
- the additive is registered pursuant to Regulation (EC) No 1907/2006,⁹ in a dossier containing
 - the information provided for by Annex VI, VII and VIII of Regulation (EC) No 1907/2006, and
 - a chemical safety report pursuant to Article 14 of Regulation (EC) No 1907/2006 covering the use as fertilising product,
 unless explicitly covered by one of the registration obligation exemptions provided for by Annex IV to that Regulation or by points 6, 7, 8, or 9 of Annex V to that Regulation, and
 - the total concentration of all additives does not exceed 5 % of the total input material weight; or
- (e) Any material listed in points (a)-(d) which
- has previously been composted or digested, and
 - contains no more than 6 mg/kg dry matter of PAH₁₆¹⁰.

2. The composting shall take place in a plant

- which only processes input materials referred to in paragraph 1 above, and
- where physical contacts between input and output materials shall be avoided, including during storage.

3. The aerobic composting shall consist in controlled decomposition of biodegradable materials, which is predominantly aerobic and which allows the development of temperatures suitable for thermophilic bacteria as a result of biologically produced heat. All parts of each batch shall be regularly and thoroughly moved in order to ensure the correct sanitation and homogeneity of the material. During the composting process, all parts of each batch shall have one of the following temperature-time profiles:

- 65°C or more for at least 5 days,
- 60°C or more for at least 7 days, or
- 55°C or more for at least 14 days.

4. The compost shall contain

- (a) no more than 6 mg/kg dry matter of PAH₁₆¹¹, and

⁹ In the case of an additive recovered in the European Union, this condition is fulfilled if the additive is the same, within the meaning of Article 2(7)(d)(i) of Regulation (EC) No 1907/2006, as a substance registered in a dossier containing the information here indicated, and if information is available to the fertilising product manufacturer within the meaning of Article 2(7)(d)(ii) of Regulation (EC) No 1907/2006.

¹⁰ Sum of naphthalene, acenaphthylene, acenaphthene, fluorene, phenanthrene, anthracene, fluoranthene, pyrene, benzo[a]anthracene, chrysene, benzo[b]fluoranthene, benzo[k]fluoranthene, benzo[a]pyrene, indeno[1,2,3-cd]pyrene, dibenzo[a,h]anthracene and benzo[ghi]perylene

¹¹ Sum of naphthalene, acenaphthylene, acenaphthene, fluorene, phenanthrene, anthracene, fluoranthene, pyrene, benzo[a]anthracene, chrysene, benzo[b]fluoranthene, benzo[k]fluoranthene, benzo[a]pyrene, indeno[1,2,3-cd]pyrene, dibenzo[a,h]anthracene and benzo[ghi]perylene

- (b) no more than 5 g/kg dry matter of macroscopic impurities in the form of glass, metal and plastics above 2 mm.
5. As of [Publications office: Please insert the date occurring 5 years after the date of application of this Regulation], the compost shall contain no more than 2,5 g/kg dry matter of macroscopic impurities in the form of plastics above 2 mm. By [Publications office: Please insert the date occurring 8 years after the date of application of this Regulation] the limit-value of 2,5 g/kg dry matter shall be reassessed in order to take into account the progress made with regards to separate collection of bio-waste.
6. The compost shall meet at least one of the following stability criteria:
- (a) Oxygen uptake rate:
- Definition: an indicator of the extent to which biodegradable organic matter is being broken down within a specified time period. The method is not suitable for material with a content of particle sizes > 10 mm exceeding 20 %,
 - Criterion: maximum 25 mmol O₂/kg organic matter/h; or
- (b) Self heating factor:
- Definition: the maximum temperature reached by a compost in standardised conditions as an indicator of the state of its aerobic biological activity,
 - Criterion: minimum Rottegrad III.

CMC 4: ENERGY CROP DIGESTATE

1. A CE marked fertilising product may contain digestate obtained through anaerobic digestion of exclusively one or more of the following input materials:
- (a) Plants that have not been used for any other purpose. For the purpose of this paragraph, plants are understood to include algae and exclude blue-green algae;
- (b) Digestion additives which are needed to improve the process performance or the environmental performance of the digestion process provided that:
- the additive is registered pursuant to Regulation (EC) No 1907/2006,¹² in a dossier containing
 - the information provided for by Annex VI, VII and VIII of Regulation (EC) No 1907/2006, and
 - a chemical safety report pursuant to Article 14 of Regulation (EC) No 1907/2006 covering the use as fertilising product,
 unless explicitly covered by one of the registration obligation exemptions provided for by Annex IV to that Regulation or by points 6, 7, 8, or 9 of Annex V to that Regulation, and

¹² In the case of an additive recovered in the European Union, this condition is fulfilled if the additive is the same, within the meaning of Article 2(7)(d)(i) of Regulation (EC) No 1907/2006, as a substance registered in a dossier containing the information here indicated, and if information is available to the fertilising product manufacturer within the meaning of Article 2(7)(d)(ii) of Regulation (EC) No 1907/2006.

- the total concentration of all additives does not exceed 5 % of the total input material weight; or
- (c) Any material referred to in points (a)-(b) that has previously been digested.
2. The anaerobic digestion shall take place in a plant
- which only processes input materials referred to in paragraph 1 above, and
 - where physical contacts between input and output materials shall be avoided, including during storage.
3. The anaerobic digestion shall consist in controlled decomposition of biodegradable materials, which is predominantly anaerobic and at temperatures suitable for mesophilic or thermophilic bacteria. All parts of each batch shall be regularly and thoroughly moved in order to ensure the correct sanitation and homogeneity of the material. During the digestion process, all parts of each batch shall have one of the following temperature-time profiles:
- (a) Thermophilic anaerobic digestion at 55°C during at least 24h and a hydraulic retention time of at least 20 days;
- (b) Thermophilic anaerobic digestion at 55°C with a treatment process including a pasteurisation step (70°C – 1h);
- (c) Thermophilic anaerobic digestion at 55°C followed by composting in
- 65°C or more for at least 5 days,
 - 60°C or more for at least 7 days, or
 - 55°C or more for at least 14 days;
- (d) Mesophilic anaerobic digestion at 37-40°C with a treatment process including a pasteurisation step (70°C – 1h); or
- (e) Mesophilic anaerobic digestion at 37-40°C followed by composting in
- 65°C or more for at least 5 days,
 - 60°C or more for at least 7 days, or
 - 55°C or more for at least 14 days.
4. Both the solid and the liquid part of the digestate shall meet at least one of the following stability criteria:
- (a) Oxygen uptake rate:
- Definition: an indicator of the extent to which biodegradable organic matter is being broken down within a specified time period. The method is not suitable for material with a content of particle sizes > 10 mm exceeding 20 %.
 - Criterion: maximum 50 mmol O₂/kg organic matter/h; or
- (b) Residual biogas potential:
- Definition: an indicator of the gas released from a digestate in a 28 day period and measured against the volatile solids contained within the sample. The test is run in triplicate, and the average result is used to demonstrate compliance with the requirement. The volatile solids are

those solids in a sample of material that are lost on ignition of the dry solids at 550°C.

- Criterion: maximum 0,45 l biogas /g volatile solids.

CMC 5: OTHER DIGESTATE THAN ENERGY CROP DIGESTATE

1. A CE marked fertilising product may contain digestate obtained through anaerobic digestion of exclusively one or more of the following input materials:
 - (a) Bio-waste within the meaning of Directive 2008/98/EC resulting from separate bio-waste collection at source;
 - (b) Animal by-products of categories 2 and 3 according to Regulation (EC) No 1069/2009;
 - (c) Living or dead organisms or parts thereof which are unprocessed or processed only by manual, mechanical or gravitational means, by dissolution in water, by flotation, by extraction with water, by steam distillation or by heating solely to remove water, or which are extracted from air by any means, except
 - the organic fraction of mixed municipal household waste separated through mechanical, physicochemical, biological and/or manual treatment,
 - sewage sludge, industrial sludge or dredging sludge,
 - animal by-products of category 1 according to Regulation (EC) No 1069/2009;
 - (d) Digestion additives which are necessary to improve the process performance or the environmental performance of the digestion process provided that
 - the additive is registered pursuant to Regulation (EC) No 1907/2006,¹³ in a dossier containing
 - the information provided for by Annex VI, VII and VIII of Regulation (EC) No 1907/2006, and
 - a chemical safety report pursuant to Article 14 of Regulation (EC) No 1907/2006 covering the use as fertilising product,unless it is covered by the registration obligation exemption provided for by Annex IV to that Regulation or by points 6, 7, 8, or 9 of Annex V to that Regulation, and
 - the total concentration of all additives does not exceed 5 % of the total input material weight; or
 - (e) Any material listed in points (a)-(d) that
 - has previously been composted or digested, and
 - contains no more than 6 mg/kg dry matter of PAH₁₆¹⁴.

¹³ In the case of an additive recovered in the European Union, this condition is fulfilled if the additive is the same, within the meaning of Article 2(7)(d)(i) of Regulation (EC) No 1907/2006, as a substance registered in a dossier containing the information here indicated, and if information is available to the fertilising product manufacturer within the meaning of Article 2(7)(d)(ii) of Regulation (EC) No 1907/2006.

2. The anaerobic digestion shall take place in a plant
 - which only processes input materials referred to in paragraph 1 above, and
 - where physical contacts between input and output materials shall be avoided, including during storage.
3. The anaerobic digestion shall constitute of controlled decomposition of biodegradable materials, which is predominantly anaerobic and at temperatures suitable for mesophilic or thermophilic bacteria. All parts of each batch shall be regularly and thoroughly moved in order to ensure the correct sanitation and homogeneity of the material. During the digestion process, all parts of each batch shall have one of the following temperature-time profiles:
 - (a) Thermophilic anaerobic digestion at 55°C during at least 24h and a hydraulic retention time of at least 20 days;
 - (b) Thermophilic anaerobic digestion at 55°C with a treatment process including a pasteurisation step (70°C – 1h);
 - (c) Thermophilic anaerobic digestion at 55°C followed by composting in
 - 65°C or more for at least 5 days,
 - 60°C or more for at least 7 days, or
 - 55°C or more for at least 14 days;
 - (d) Mesophilic anaerobic digestion at 37-40°C with a treatment process including a pasteurisation step (70°C – 1h); or
 - (e) Mesophilic anaerobic digestion at 37-40°C followed by composting in
 - 65°C or more for at least 5 days,
 - 60°C or more for at least 7 days, or
 - 55°C or more for at least 14 days.
4. Neither the solid, nor the liquid part of the digestate shall contain more than 6 mg/kg dry matter of PAH₁₆¹⁵.
5. The digestate shall contain no more than 5 g/kg dry matter of macroscopic impurities in the form of glass, metal and plastics above 2 mm.
6. As of [Publications office: Please insert the date occurring 5 years after the date of application of this Regulation], the digestate shall contain no more than 2,5 g/kg dry matter of macroscopic impurities in the form of plastics above 2 mm. By [Publications office: Please insert the date occurring 8 years after the date of application of this Regulation] the limit-value of 2,5 g/kg dry matter shall be re-assessed in order to take into account the progress made with regards to separate collection of bio-waste.

¹⁴ Sum of naphthalene, acenaphthylene, acenaphthene, fluorene, phenanthrene, anthracene, fluoranthene, pyrene, benzo[a]anthracene, chrysene, benzo[b]fluoranthene, benzo[k]fluoranthene, benzo[a]pyrene, indeno[1,2,3-cd]pyrene, dibenzo[a,h]anthracene and benzo[ghi]perylene

¹⁵ Sum of naphthalene, acenaphthylene, acenaphthene, fluorene, phenanthrene, anthracene, fluoranthene, pyrene, benzo[a]anthracene, chrysene, benzo[b]fluoranthene, benzo[k]fluoranthene, benzo[a]pyrene, indeno[1,2,3-cd]pyrene, dibenzo[a,h]anthracene and benzo[ghi]perylene

7. Both the solid and the liquid part of the digestate shall meet at least one of the following stability criteria:
- (a) Oxygen uptake rate:
 - Definition: an indicator of the extent to which biodegradable organic matter is being broken down within a specified time period. The method is not suitable for material with a content of particle sizes > 10 mm exceeding 20 %.
 - Criterion: maximum 50 mmol O₂/kg organic matter/h; or
 - (b) Residual biogas potential:
 - Definition: an indicator of the gas released from a digestate in a 28 day period and measured against the volatile solids contained within the sample. The test is run in triplicate, and the average result is used to demonstrate compliance with the requirement. The volatile solids are those solids in a sample of material that are lost on ignition of the dry solids at 550°C.
 - Criterion: maximum 0,45 l biogas /g volatile solids.

CMC 6: FOOD INDUSTRY BY-PRODUCTS

1. A CE marked fertilising product may contain component material consisting of one of the following substances:
- (a) food industry factory lime, *i.e.* a material from the food processing industry obtained by carbonation of organic matter, using exclusively burnt lime from natural sources;
 - (b) molasses, *i.e.* a viscous by-product of the refining of sugarcane or sugar beets into sugar; or
 - (c) vinasse, *i.e.* a viscous by-product of the fermentation process of molasses into ethanol, ascorbic acid or other products.
2. The substance shall have been registered pursuant to Regulation (EC) No 1907/2006,¹⁶ in a dossier containing
- (a) the information provided for by Annex VI, VII and VIII of Regulation (EC) No 1907/2006, and
 - (b) a chemical safety report pursuant to Article 14 of Regulation (EC) No 1907/2006 covering the use as fertilising product,
- unless explicitly covered by one of the registration obligation exemptions provided for by Annex IV to that Regulation or by points 6, 7, 8, or 9 of Annex V to that Regulation.

¹⁶ In the case of a substance recovered in the European Union, this condition is fulfilled if the substance is the same, within the meaning of Article 2(7)(d)(i) of Regulation (EC) No 1907/2006, as a substance registered in a dossier containing the information here indicated, and if information is available to the fertilising product manufacturer within the meaning of Article 2(7)(d)(ii) of Regulation (EC) No 1907/2006.

CMC 7: MICRO-ORGANISMS

A CE marked fertilising product may contain micro-organisms, including dead or empty-cell micro-organisms and non-harmful residual elements of the media on which they were produced, which

- have undergone no other processing than drying or freeze-drying and
- are listed in the table below:

<i>Azotobacter spp.</i>
<i>Mycorrhizal fungi</i>
<i>Rhizobium spp.</i>
<i>Azospirillum spp.</i>

CMC 8: AGRONOMIC ADDITIVES

1. A CE marked fertilising product may contain a substance or a mixture intended to improve the fertilising product's nutrient release patterns, only if that substance's or mixture's compliance with the requirements of this Regulation for a product in PFC 5 of Annex I has been demonstrated in accordance with the conformity assessment procedure applicable to such an agronomic additive.
2. The quantity of the compliant agronomic additive in the CE marked fertilising product shall be such as
 - (a) to produce the effect claimed in the information provided to the user of the CE marked fertilising products, and
 - (b) not to cause an overall adverse effect on human, animal or plant health, on safety, or on the environment, under reasonably foreseeable conditions of storage or use of the CE marked fertilising product.
3. A CE marked fertilising product may contain a compliant nitrification inhibitor, as referred to in PFC 5(A)(I) of Annex I, only if at least 50% of the total nitrogen (N) content of the fertilising product consists of the nitrogen (N) forms ammonium (NH₄⁺) and urea (CH₄N₂O).
4. A CE marked fertilising product may contain a compliant urease inhibitor, as referred to in PFC 5(A)(II) of Annex I, only if at least 50% of the total nitrogen (N) content of the fertilising product consists of the nitrogen (N) form urea (CH₄N₂O).
5. The manufacturer of the CE marked fertilising product shall be in possession of the EU declaration of conformity of the compliant agronomic additive.
6. Economic operators making the CE marked fertilising product available on the market shall respect the following provisions of this Regulation with regard to the EU declarations of conformity of both the CE marked fertilising product and the compliant agronomic additive:
 - (a) Article 6(3) (manufacturers' obligation to keep the EU declaration of conformity);

- (b) Article 7(2)(a) (authorised representatives' obligation to keep the EU declaration of conformity);
- (c) Article 8(2) (importers' obligation to ensure that the CE marked fertilising product is accompanied by the EU declaration of conformity);
- (d) Article 8(8) (importers' obligation to keep a copy of the EU declaration of conformity at the disposal of the market surveillance authorities); and
- (e) Article 9(2) (distributors' obligation to verify that the CE marked fertilising product is accompanied by the EU declaration of conformity).

CMC 9: NUTRIENT POLYMERS

1. A CE marked fertilising product may contain polymers exclusively made up of monomer substances complying with the description in CMC 1, where the purpose of the polymerisation is to control the release of nutrients from one or more of the monomer substances.
2. At least 3/5 of the polymers shall be soluble in hot water.
3. The polymers shall not contain formaldehyde.

CMC 10: OTHER POLYMERS THAN NUTRIENT POLYMERS

1. A CE marked fertilising product may contain other polymers than nutrient polymers only in cases where the purpose of the polymer is that of
 - (a) controlling the water penetration into nutrient particles and thus the release of nutrients (in which case the polymer is commonly referred to as a 'coating agent'), or
 - (b) increasing the water retention capacity of the CE marked fertilising product.
2. As of [Publications office, please insert the date occurring three years after the date of application of this Regulation], the following criterion shall be complied with: The polymer shall be capable of undergoing physical, biological decomposition, such that most of it ultimately decomposes into carbon dioxide (CO₂), biomass and water. It shall have at least 90 % of the organic carbon converted into CO₂ in maximum 24 months, in a biodegradability test as specified points (a)-(c) below.
 - (a) The test shall be conducted at 25°C ± 2°C.
 - (b) The test shall be conducted in accordance with a method for determining the ultimate aerobic biodegradability of plastic materials in soils by measuring oxygen demand or the amount of carbon dioxide evolved.
 - (c) A micro-crystalline cellulose powder with the same dimension as the test material shall be used as a reference material in the test.
 - (d) Prior to the test, the test material shall not be subject to conditions or procedures designed to accelerate the degradation of the film, such as exposure to heat or light.
3. Neither the polymer, nor its degradation by-products, shall show any overall adverse effect on animal or plant health, or on the environment, under reasonably foreseeable conditions of use in the CE marked fertilising product. The polymer shall pass a plant

growth acute toxicity test, an earthworm acute toxicity test and a nitrification inhibition test with soil micro-organisms as follows:

- (a) In the plant growth acute toxicity test, the germination rate and the plant biomass of the tested plant species grown on the soil exposed to the test material shall be more than 90 % of the germination rate and the plant biomass of the same plant species grown on corresponding blank soil not exposed to the test material.
- (b) The results shall be considered valid only if in the controls (*i.e.* blank soil):
 - the seedling emergence is at least 70 %;
 - the seedlings do not exhibit visible phytotoxic effects (e.g. chlorosis, necrosis, wilting, leaf and stem deformations) and the plants exhibit only normal variation in growth and morphology for that particular species;
 - the mean survival of emerged control seedlings is at least 90 % for the duration of the study; and
 - environmental conditions for a particular species are identical and growing media contain the same amount of soil matrix, support media, or substrate from the same source.
- (c) In the earthworm acute toxicity test, the observed mortality and the biomass of surviving earthworms in a soil exposed to the test material shall not differ by more than 10 % compared to those from the corresponding blank soil not exposed to the test material. The results shall be considered to be valid, if
 - the percent mortality observed in the control (*i.e.* blank soil) is < 10 %, and
 - the average loss of biomass (mean weight) of the worms in the blank soil does not exceed 20 %.
- (d) In the nitrification inhibition test with soil micro-organisms, the nitrite formation in soil exposed to the test material shall be more than 90 % of those from the corresponding blank soil not exposed to the test material. The results shall be considered to be valid, if the variation between replicate control samples (blank soil) and test samples is less than ± 20 %.

CMC 11: CERTAIN ANIMAL BY-PRODUCTS

A CE marked fertilising product may contain animal by-products within the meaning of Regulation (EC) No 1069/2009 having reached the end point in the manufacturing chain as determined in accordance with that Regulation, which are listed in the table below and as specified therein:

--

ANNEX III
Labelling requirements

This Annex sets out the labelling requirements for CE marked fertilising products. The requirements laid down in Part 2 and Part 3 of this Annex for a given Product Function Category ('PFC'), as specified in Annex I, apply to CE marked fertilising products in all subcategories of that PFC.

PART 1
GENERAL LABELLING REQUIREMENTS

1. The information elements required by this Regulation shall be clearly separated from any other information elements.
2. The following information elements shall be provided:
 - (a) The designation of the Product Function Category ('PFC') as indicated in Part I of Annex I;
 - (b) The quantity of the CE marked fertilising product, indicated by mass or volume;
 - (c) Instructions for intended use, including intended application rate and intended target plants;
 - (d) Any relevant information on measures recommended to manage risks to human, animal or plant health, safety, or the environment; and
 - (e) A description of all components above 5% by product weight in descending order of magnitude by dry weight, including an indication of the relevant component material categories ('CMC') as referred to in Annex II.
3. Where the conformity assessment procedure has involved a notified body, the identification number of the notified body shall be indicated.
4. Where the CE marked fertilising product contains animal by-products within the meaning of Regulation (EC) No 1069/2009 other than manure, it shall carry the following user instruction: 'Farmed animals shall not be fed, either directly or by grazing, with herbage from land to which the product has been applied unless the cutting or grazing takes place after the expiry of a waiting period of at least 21 days.'
5. Where the CE marked fertilising product contains a substance for which maximum residue limits for food and feed have been established in accordance with Regulation (EEC) No 315/93, Regulation (EC) No 396/2005, Regulation (EC) No 470/2009 or Directive 2002/32/EC, the instructions referred to in paragraph 2(c) shall ensure that the intended use of the CE marked fertilising product does not lead to the exceedance of those limits in food or feed.
6. The designation of a product function category ('PFC'), as indicated in Annex I, must not be indicated on a CE marked fertilising product which has not been subject of a successful conformity assessment in accordance with this Regulation for that PFC.
7. Information elements other than those required under paragraphs 2-6
 - (a) shall not mislead the user, for example by attributing to the product properties that it does not possess, or by suggesting that the product possesses unique characteristics which similar products also have;

- (b) shall relate to verifiable factors; and
 - (c) shall not make claims such as 'sustainable' or 'environmentally friendly' unless such claims can be objectively verified against widely recognised guidance, standards or schemes.
8. The phrase 'poor in chloride' or similar may only be used if the chloride (Cl⁻) content is below 30 g/kg.

PART 2

PRODUCT-SPECIFIC LABELLING REQUIREMENTS

PFC 1: FERTILISER

1. The content of nitrogen (N), phosphorus (P) and potassium (K) shall be declared only where those nutrients are present in the CE marked fertilising product in the minimum quantity specified in Annex I for the relevant product function category (PFC).
2. The following rules apply to fertilisers containing nitrification or urease inhibitors, as specified in paragraphs 3 and 4 of component material category ('CMC') 8 in Annex II:
 - (a) The label shall state the words "nitrification inhibitor" or "urease inhibitor", as relevant, as well as the identification number of the notified body having examined the conformity assessment of the nitrification inhibitor or the urease inhibitor.
 - (b) The nitrification inhibitor content shall be expressed as a percentage by mass of the total nitrogen (N) present as ammonium nitrogen (NH₄⁺) and urea nitrogen (CH₄N₂O).
 - (c) The urease inhibitor content shall be expressed as a percentage by mass of the total nitrogen (N) present as urea nitrogen (CH₄N₂O).
 - (d) Technical information shall be provided enabling the user to determine the rates and timing of application in relation to the crop being grown.

PFC 1(A): Organic fertiliser

The following information elements shall be present:

- (a) the declared nutrients nitrogen (N), phosphorus (P) or potassium (K), by their chemical symbols in the order N-P-K;
- (b) the declared nutrients magnesium (Mg), calcium (Ca), sulphur (S) or sodium (Na), by their chemical symbols in the order Mg-Ca-S-Na;
- (c) numbers indicating the total content of the declared nutrients nitrogen (N), phosphorus (P) or potassium (K), followed by numbers in brackets indicating the total content of magnesium (Mg), calcium (Ca), sulphur (S) or sodium (Na),

- (d) the content of the following declared nutrients and other parameters, in the following order and as a percentage of the fertiliser by mass,
- Total Nitrogen (N)
 - minimum amount of organic nitrogen (N), followed by a description of the origin of the organic matter used;
 - Nitrogen (N) in the form of ammoniacal nitrogen;
 - Total phosphorus pentoxide (P₂O₅);
 - Total potassium oxide (K₂O);
 - Magnesium oxide (MgO), calcium oxide (CaO), sulphur trioxide (SO₃) and sodium oxide (Na₂O), expressed
 - where those nutrients are totally soluble in water, only as the content soluble in water;
 - where the soluble content of those nutrients is at least a quarter of the total content of those nutrients, the total content and the content soluble in water; and
 - in other cases, as the total content;
 - Total copper (Cu) and zinc (Zn), if above 200 and 600 mg/kg dry matter respectively;
 - Organic carbon (C); and
 - Dry matter.

PFC 1(B): Organo-mineral fertiliser

1. The following information elements relating to macronutrients shall be present:
- (a) the declared nutrients nitrogen (N), phosphorus (P) or potassium (K), by their chemical symbols in the order N-P-K;
 - (b) the declared nutrients magnesium (Mg), calcium (Ca), sulphur (S) or sodium (Na), by their chemical symbols in the order Mg-Ca-S-Na;
 - (c) numbers indicating the total content of the declared nutrients nitrogen (N), phosphorus (P) or potassium (K), followed by numbers in brackets indicating the total content of magnesium (Mg), calcium (Ca), sulphur (S) or sodium (Na);
 - (d) the content of the following declared nutrients, in the following order and as a percentage of the fertiliser by mass:
 - Total Nitrogen (N)
 - minimum amount of organic nitrogen (N), followed by a description of the origin of the organic matter used;
 - Nitrogen (N) in the form of nitric nitrogen;
 - Nitrogen (N) in the form of ammoniacal nitrogen;
 - Nitrogen (N) in the form of urea nitrogen;

- Total phosphorus pentoxide (P₂O₅);
 - Water-soluble phosphorus pentoxide (P₂O₅);
 - phosphorus pentoxide (P₂O₅) soluble in neutral ammonium citrate;
 - where soft ground phosphate is present, phosphorus pentoxide (P₂O₅) soluble in formic acid;
 - Total potassium oxide (K₂O);
 - Water soluble potassium oxide (K₂O);
 - magnesium oxide (MgO), calcium oxide (CaO), sulphur trioxide (SO₃) and sodium oxide (Na₂O), expressed
 - where those nutrients are totally soluble in water, only as the content soluble in water;
 - where the soluble content of those nutrients is at least a quarter of the total content of those nutrients, the total content and the content soluble in water;
 - in other cases, as the total content, and
- (e) where urea (CH₄N₂O) is present, information about the possible air quality impacts of the release of ammonia from the fertiliser use, and an invitation to users to apply appropriate remediation measures.

2. The following other elements shall be indicated as a percentage by mass of the CE marked fertilising product:

- Organic carbon (C) content; and
- Dry matter content.

PFC 1(B)(I): Solid organo-mineral fertiliser

Where one or more of the micronutrients boron (B), cobalt (Co), copper (Cu), iron (Fe), manganese (Mn), molybdenum (Mo) and zinc (Zn), are present in the minimum content indicated as a percentage by mass in the table below, they

- shall be declared if they are intentionally added to the CE marked fertilising product, and
- may be declared in other cases:

Micronutrient	Intended for use on crops or grassland	Intended for horticultural use
Boron (B)	0,01	0,01
Cobalt (Co)	0,002	n.a.
Copper (Cu)	0,01	0,002
Iron (Fe)	0,5	0,02
Manganese (Mn)	0,1	0,01

Molybdenum (Mo)	0,001	0,001
Zinc	0,01	0,002

They shall be declared after the information on macronutrients. The following information elements shall be present:

- (a) indication of the names and chemical symbols of the declared micronutrients, listed in the following order: boron (B), cobalt (Co), copper (Cu), iron (Fe), manganese (Mn), molybdenum (Mo) and zinc (Zn), followed by the name(s) of their counter-ion(s);
- (b) The total micronutrient content expressed as a percentage of the fertiliser by mass
 - where those nutrients are totally soluble in water, only as the content soluble in water;
 - where the soluble content of those nutrients is at least a quarter of the total content of those nutrients, the total content and the content soluble in water; and
 - in other cases, as the total content;
- (c) Where the declared micronutrient(s) are chelated by chelating agent(s), the following qualifier after the name and the chemical identifier of the micronutrient:
 - ‘chelated by...’ name of the chelating agent or its abbreviation, and the amount of chelated micronutrient as a percentage of the CE marked fertilising product by mass;
- (d) Where the CE marked fertilising product contains micronutrient(s) complexed by complexing agent(s):
 - the following qualifier after the name and the chemical identifier of the micronutrient: ‘complexed by ...’, and the amount of complexed micronutrient as a percentage of the CE marked fertilising product by mass; and
 - the name of the complexing agent or its abbreviation.
- (e) The following statement: ‘To be used only where there is a recognised need. Do not exceed the appropriate rate’.

PFC 1(B)(II): Liquid organo-mineral fertiliser

Where one or more of the micronutrients boron (B), cobalt (Co), copper (Cu), iron (Fe), manganese (Mn), molybdenum (Mo) and zinc (Zn), are present in the minimum content indicated as a percentage by mass in the table below, they

- shall be declared if they are intentionally added to the CE marked fertilising product, and

- may be declared in other cases:

Micronutrient	Percentage by mass
Boron (B)	0,01
Cobalt (Co)	0,002
Copper (Cu)	0,002
Iron (Fe)	0,02
Manganese (Mn)	0,01
Molybdenum (Mo)	0,001
Zinc	0,002

They shall be declared after the information on macronutrients. The following information elements shall be present:

- (a) indication of the names and chemical symbols of the declared micronutrients, listed in the following order: boron (B), cobalt (Co), copper (Cu), iron (Fe), manganese (Mn), molybdenum (Mo) and zinc (Zn), followed by the name(s) of their counter-ion(s);
- (b) The total micronutrient content expressed as a percentage of the fertiliser by mass
 - where those nutrients are totally soluble in water, only as the content soluble in water;
 - where the soluble content of those nutrients is at least a quarter of the total content of those nutrients, the total content and the content soluble in water; and
 - in other cases, as the total content;
- (c) Where the declared micronutrient(s) are chelated by chelating agent(s), the following qualifier after the name and the chemical identifier of the micronutrient:
 - ‘chelated by...’ name of the chelating agent or its abbreviation, and the amount of chelated micronutrient as a percentage of the CE marked fertilising product by mass;
- (d) Where the CE marked fertilising product contains micronutrient(s) complexed by complexing agent(s):
 - the following qualifier after the name and the chemical identifier of the micronutrient: ‘complexed by ...’, and the amount of complexed micronutrient as a percentage of the CE marked fertilising product by mass; and
 - the name of the complexing agent or its abbreviation.
- (e) The following statement: ‘To be used only where there is a recognised need. Do not exceed the appropriate rate’.

PFC 1(C): Inorganic fertiliser

PFC 1(C)(I): Inorganic macronutrient fertiliser

1. The following information elements relating to macronutrients shall be present:
 - (a) the declared nutrients nitrogen (N), phosphorus (P) or potassium (K), by their chemical symbols in the order N-P-K;
 - (b) the declared nutrients magnesium (Mg), calcium (Ca), sulphur (S) or sodium (Na), by their chemical symbols in the order Mg-Ca-S-Na;
 - (c) numbers indicating the total content of the declared nutrients nitrogen (N), phosphorus (P) or potassium (K), followed by numbers in brackets indicating the total content of magnesium (Mg), calcium (Ca), sulphur (S) or sodium (Na);
 - (d) the content of the following declared nutrients, in the following order and as a percentage of the fertiliser by mass,
 - Total Nitrogen (N);
 - Nitrogen (N) in the form of nitric nitrogen
 - Nitrogen (N) in the form of ammoniacal nitrogen;
 - Nitrogen (N) in the form of urea nitrogen;
 - Nitrogen (N) from urea formaldehyde, isobutylidenediurea, crotonylidenediurea;
 - Nitrogen (N) from cyanamide nitrogen;
 - Total phosphorus pentoxide (P₂O₅);
 - Water-soluble phosphorus pentoxide (P₂O₅);
 - phosphorus pentoxide (P₂O₅) soluble in neutral ammonium citrate;
 - where soft ground phosphate is present, phosphorus pentoxide (P₂O₅) soluble in formic acid;
 - Water soluble potassium oxide (K₂O);
 - magnesium oxide (MgO), calcium oxide (CaO), sulphur trioxide (SO₃) and sodium oxide (Na₂O), expressed
 - where those nutrients are totally soluble in water, only as the content soluble in water;
 - where the soluble content of those nutrients is at least a quarter of the total content of those nutrients, the total content and the content soluble in water; and
 - in other cases, as the total content, and
 - (e) where urea (CH₄N₂O) is present, information about the possible air quality impacts of the release of ammonia from the fertiliser use, and an invitation to users to apply appropriate remediation measures.

PFC 1(C)(I)(a): Solid inorganic macronutrient fertiliser

1. The fertiliser shall be labelled
 - (a) 'complex', where each particle contains all the declared nutrients in their declared content, and
 - (b) 'mix' in other cases.
2. The granulometry of the fertiliser shall be indicated, expressed a percentage of product passing through a determined sieve.
3. The particle form of the product shall be indicated with one of the following mentions:
 - (a) Granule,
 - (b) pellet,
 - (c) powder, where at least 90% of the product can pass through a sieve with a mesh of 10 mm, or
 - (d) prill.
4. For coated fertilisers, the name of the coating agent(s) and the percentage of fertilisers coated by each coating agent(s) shall be indicated and followed by:
 - (a) Release time defined in months of the coated fraction(s) followed by the percentage of nutrients released during this time for each fraction;
 - (b) The name of the medium (solvent or substrate) used in the test performed by the manufacturer for determining the release time;
 - (c) The temperature at which the test was conducted;
 - (d) For polymer coated fertilisers, the following marking: 'The rate of nutrient releases can vary according to the temperature of the substrate. An adjustment of fertilisation may be necessary'; and
 - (e) For sulphur (S) coated fertilisers and sulphur (S)/polymer coated fertilisers, the following marking: 'The rate of nutrient release can vary according to the temperature of the substrate and the biological activity. An adjustment of fertilisation may be necessary'.
5. Where one or more of the micronutrients boron (B), cobalt (Co), copper (Cu), iron (Fe), manganese (Mn), molybdenum (Mo) and zinc (Zn), are present in the minimum content indicated below as a percentage by mass, they
 - shall be declared if they are intentionally added to the CE marked fertilising product, and
 - may be declared in other cases:

Micronutrient	Intended for use on crops or grassland	Intended for horticultural use
Boron (B)	0,01	0,01
Cobalt (Co)	0,002	n.a.

Copper (Cu)	0,01	0,002
Iron (Fe)	0,5	0,02
Manganese (Mn)	0,1	0,01
Molybdenum (Mo)	0,001	0,001
Zinc	0,01	0,002

They shall be declared after the information on macronutrients. The following information elements shall be present:

- (a) indication of the names and chemical symbols of the declared micronutrients, listed in the following order: boron (B), cobalt (Co), copper (Cu), iron (Fe), manganese (Mn), molybdenum (Mo) and zinc (Zn), followed by the name(s) of their counter-ion(s);
- (b) The total micronutrient content expressed as a percentage of the fertiliser by mass
 - where those nutrients are totally soluble in water, only as the content soluble in water;
 - where the soluble content of those nutrients is at least a quarter of the total content of those nutrients, the total content and the content soluble in water; and
 - in other cases, as the total content;
- (c) Where the declared micronutrient(s) are chelated by chelating agent(s), the following qualifier after the name and the chemical identifier of the micronutrient:
 - ‘chelated by...’ name of the chelating agent or its abbreviation, and the amount of chelated micronutrient as a percentage of the CE marked fertilising product by mass;
- (d) Where the CE marked fertilising product contains micronutrient(s) complexed by complexing agent(s):
 - the following qualifier after the name and the chemical identifier of the micronutrient: ‘complexed by ...’, and the amount of complexed micronutrient as a percentage of the CE marked fertilising product by mass; and
 - the name of the complexing agent or its abbreviation.
- (e) The following statement: ‘To be used only where there is a recognised need. Do not exceed the appropriate rate’.

PFC 1(C)(I)(b): Liquid inorganic macronutrient fertiliser

1. The label shall indicate whether the fertiliser is in suspension or in solution, where
 - a suspension means a two-phase dispersion in which solid particles are maintained in suspension in the liquid phase, and

- a solution means a liquid that is free of solid particles.
2. The nutrient content shall be indicated as a percentage by mass or volume of the CE marked fertilising product.
 3. Where one or more of the micronutrients boron (B), cobalt (Co), copper (Cu), iron (Fe), manganese (Mn), molybdenum (Mo) and zinc (Zn), are present in the minimum content indicated below as a percentage by mass, they
 - shall be declared if they are intentionally added to the CE marked fertilising product, and
 - may be declared in other cases:

Micronutrient	Percentage by mass
Boron (B)	0,01
Cobalt (Co)	0,002
Copper (Cu)	0,002
Iron (Fe)	0,02
Manganese (Mn)	0,01
Molybdenum (Mo)	0,001
Zinc	0,002

They shall be declared after the information on macronutrients. The following information elements shall be present:

- (a) indication of the names and chemical symbols of the declared micronutrients, listed in the following order: boron (B), cobalt (Co), copper (Cu), iron (Fe), manganese (Mn), molybdenum (Mo) and zinc (Zn), followed by the name(s) of their counter-ion(s);
- (b) The total micronutrient content expressed as a percentage of the fertiliser by mass
 - where those nutrients are totally soluble in water, only as the content soluble in water;
 - where the soluble content of those nutrients is at least a quarter of the total content of those nutrients, the total content and the content soluble in water; and
 - in other cases, as the total content;
- (c) Where the declared micronutrient(s) are chelated by chelating agent(s), the following qualifier after the name and the chemical identifier of the micronutrient:
 - ‘chelated by...’ name of the chelating agent or its abbreviation, and the amount of chelated micronutrient as a percentage of the CE marked fertilising product by mass;

- (d) Where the CE marked fertilising product contains micronutrient(s) complexed by complexing agent(s):
- the following qualifier after the name and the chemical identifier of the micronutrient: ‘complexed by ...’, and the amount of complexed micronutrient as a percentage of the CE marked fertilising product by mass; and
 - the name of the complexing agent or its abbreviation.
- (e) The following statement: ‘To be used only where there is a recognised need. Do not exceed the appropriate rate’.

PFC 1(C)(II): Inorganic micronutrient fertiliser

1. The declared micronutrients in the CE marked fertilising product shall be listed by their names and chemical symbols in the following order: boron (B), cobalt (Co), copper (Cu), iron (Fe), manganese (Mn), molybdenum (Mo) and zinc (Zn), followed by the name(s) of their counter-ion(s),
2. Where the declared micronutrient(s) are chelated by chelating agent(s), and each chelating agent can be identified and quantified and chelates at least 1% water-soluble micronutrient, the following qualifier shall be added after the name and the chemical identifier of the micronutrient:
 - ‘chelated by...’ name of the chelating agent or its abbreviation, and the amount of chelated micronutrient as a percentage of the CE marked fertilising product by mass.
3. Where the declared micronutrient(s) are complexed by complexing agent(s), the following qualifier shall be added after the name and the chemical identifier of the micronutrient:
 - ‘complexed by ...’, and the amount of complexed micronutrient as a percentage of the CE marked fertilising product by mass, and
 - the name of the complexing agent or its abbreviation.
4. The following statement shall appear: ‘To be used only where there is a recognised need. Do not exceed the appropriate rate’.

PFC 1(C)(II)(a): Straight inorganic micronutrient fertiliser

1. The label shall indicate the relevant typology, as referred to in the table under PFC 1(C)(II)(a) in Part II of Annex I.
2. The total micronutrient content shall be expressed as a percentage of the fertiliser by mass
 - where the micronutrient is totally soluble in water, only as the content soluble in water;
 - where the soluble content of the micronutrient is at least a quarter of the total content of that nutrient, the total content and the content soluble in water; and
 - in other cases, as the total content.

PFC 1(C)(II)(b): Compound inorganic micronutrient fertiliser

1. Micronutrients can be declared only if they are present in the fertiliser in the following quantities:

Micronutrient	Non-chelated, non-complexed	Chelated or complexed
Boron (B)	0,2	n.a.
Cobalt (Co)	0,02	0,02
Copper (Cu)	0,5	0,1
Iron (Fe)	2	0,3
Manganese (Mn)	0,5	0,1
Molybdenum (Mo)	0,02	n.a.
Zinc	0,5	0,1

2. If the fertiliser is in suspension or in solution, the label shall indicate "in suspension" or "in solution", as relevant.
3. The total micronutrient content shall be expressed as a percentage of the fertiliser by mass
- where the micronutrients are totally soluble in water, only as the content soluble in water;
 - where the soluble content of the micronutrients is at least half of the total content of those nutrients, the total content and the content soluble in water; and
 - in other cases, as the total content.

PFC 2: LIMING MATERIAL

The following parameters shall be declared in the following order:

- Neutralising value;
- Granulometry, expressed a percentage of product passing through a determined sieve;
- Total CaO, expressed as a percentage by mass of the CE marked fertilising product;
- Total MgO, expressed as a percentage by mass of the CE marked fertilising product;
- Reactivity, except for oxide and hydroxide limes; and
- for slags and carbonates of natural origin: method of determination of reactivity.

PFC 3: SOIL IMPROVER

The following parameters shall be declared in the following order, and expressed as a percentage of the CE marked fertilising product by mass:

- Dry matter;

- Organic carbon (C) content;
- Total nitrogen (N) content;
- Total phosphorus pentoxide (P₂O₅) content;
- Total potassium oxide (K₂O) content;
- Total copper (Cu) and zinc (Zn) content, if above 200 and 600 mg/kg dry matter respectively; and
- pH.

PFC 4: GROWING MEDIUM

The parameters shall be declared in the following order:

- Electrical conductivity, except for mineral wool;
- pH;
- Quantity
 - For mineral wool, expressed as number of pieces and the three dimensions length, height, and width,
 - For other pre-shaped growing media, expressed as size in at least two dimensions, and
 - For other growing media, expressed as total volume;
- Except for pre-shaped growing media, quantity expressed as volume of materials with a particle size greater than 60 mm;
- Total nitrogen (N);
- Total phosphorus pentoxide (P₂O₅); and
- Total potassium oxide (K₂O).

PFC 5: AGRONOMIC ADDITIVE

Only the general labelling requirements apply to this PFC.

PFC 6: PLANT BIOSTIMULANT

The following information elements shall be present:

- (a) physical form;
- (b) manufacturing and expiry date;
- (c) storage conditions;
- (d) application method(s);
- (e) dose, timing (plant development stage) and frequency of application;
- (f) effect claimed for each target plant; and
- (g) any relevant instructions related to the efficacy of the product, including soil management practices, chemical fertilisation, incompatibility with plant protection products, recommended spraying nozzles size and sprayer pressure.

PFC 6(A): Microbial plant biostimulant

The label shall contain the following phrase: 'Micro-organisms may have the potential to provoke sensitising reactions'.

PFC 7: FERTILISING PRODUCT BLEND

All the labelling requirements applicable to all component CE marked fertilising products apply to the CE marked fertilising product blend, and shall be expressed in relation to the final CE marked fertilising product blend.

**PART 3
TOLERANCE RULES**

1. The declared nutrient content or physico-chemical characteristics of a CE marked fertilising product may deviate from the actual value only in accordance with the tolerances established in this Part for the relevant product function category. The tolerances are intended to allow for deviations in manufacture, sampling and analysis.
2. The tolerances allowed in respect of the declared parameters indicated in this Part are negative and positive values in percentage by mass.
3. The manufacturer, importer or distributor shall not take systematic advantage of the tolerances.
4. By derogation from paragraph 1, the actual content in a CE marked fertilising product of a component for which a minimum or a maximum content is specified in Annex I or Annex II may never be lower than the minimum content or exceed the maximum content.

PFC 1: FERTILISER

PFC 1(A): Organic fertiliser

	Permissible tolerance for the declared nutrient content and other declared parameter
Organic carbon (C)	± 20 % relative deviation of the declared value up to a maximum of 2,0 percentage point in absolute terms
Dry matter content	± 5,0 percentage point in absolute terms
Total nitrogen (N)	± 50 % relative deviation of the declared value up to a maximum of 1,0 percentage point in absolute terms
Organic nitrogen (N)	± 50 % relative deviation of the declared value up to a maximum of 1,0 percentage point in absolute terms
Total phosphorus pentoxide (P ₂ O ₅)	± 50 % relative deviation of the declared value up to a maximum of 1,0 percentage point in absolute terms
Total potassium oxide (K ₂ O)	± 50 % relative deviation of the declared value up to a maximum of 1,0 percentage point in absolute terms

Total and water-soluble magnesium oxide, calcium oxide, sulphur trioxide or sodium oxide	± 25% of the declared content of those nutrients up to a maximum of 1,5 percentage points in absolute terms.
Total copper (Cu)	± 50 % relative deviation of the declared value up to a maximum of 2,5 percentage points in absolute terms
Total zinc (Zn)	± 50 % relative deviation of the declared value up to a maximum of 2,0 percentage points in absolute terms
Quantity	- 5 % relative deviation of the declared value

PFC 1(B): Organo-mineral fertiliser

Permissible tolerance for the declared content of forms of inorganic macronutrient						
N	P ₂ O ₅	K ₂ O	MgO	CaO	SO ₃	Na ₂ O
± 25% of the declared content of the nutrient forms present up to a maximum of 2 percentage point in absolute terms			± 25% of the declared content of those nutrients up to a maximum of 1,5 percentage points in absolute terms.			± 25% of the declared content up to a maximum of 0,9 percentage points in absolute terms

Micro-nutrient fertilisers	Permissible tolerance for the declared content of forms of micronutrient
Concentration below or equal to 2%	± 20 % of the declared value
Concentration of between 2,1% and 10%	± 0,3 percentage points in absolute terms
Concentration of more than 10%	± 1,0 percentage points in absolute terms

Organic carbon: ± 20 % relative deviation of the declared value up to a maximum of 2,0 percentage point in absolute terms

Organic nitrogen: ± 50 % relative deviation of the declared value up to a maximum of 1,0 percentage point in absolute terms

Total copper (Cu) ± 50 % relative deviation of the declared value up to a maximum of 2,5 percentage points in absolute terms

Total zinc (Zn) ± 50 % relative deviation of the declared value up to a maximum of 2,0 percentage points in absolute terms

Dry matter content: ± 5,0 percentage point in absolute terms

Quantity: -5% relative deviation of the declared value

PFC 1(C): Inorganic fertiliser***PFC 1(C)(I): Inorganic macronutrient fertiliser***

Permissible tolerance for the declared content of forms of macronutrient						
N	P ₂ O ₅	K ₂ O	MgO	CaO	SO ₃	Na ₂ O
± 25% of the declared content of the nutrient forms present up to a maximum of 2 percentage point in absolute terms			± 25% of the declared content of those nutrients up to a maximum of 1,5 percentage points in absolute terms.			± 25% of the declared content up to a maximum of 0,9 percentage points in absolute terms

Granulometry: ± 10 % relative deviation applicable to the declared percentage of material passing a specific sieve

Quantity: ± 5 % relative deviation of the declared value

PFC 1(C)(II): Inorganic micronutrient fertiliser

Micro-nutrient fertilisers	Permissible tolerance for the declared content of forms of micro-nutrient
Concentration below or equal to 2%	± 20 % of the declared value
Concentration of between 2,1% and 10%	± 0,3 percentage points in absolute terms
Concentration of more than 10%	± 1,0 percentage points in absolute terms

Quantity: ± 5 % relative deviation of the declared value

PFC 2: LIMING MATERIAL

	Permissible tolerances for the declared parameter
Neutralising value	± 3
Granulometry	± 10 % relative deviation applicable to the declared percentage of material passing a specific sieve.
Total calcium oxide	± 3 percentage points in absolute terms
Total magnesium oxide	
Concentration below 8%	± 1,0 percentage points in absolute terms
Concentration between 8 to 16%	± 2,0 percentage points in absolute terms
Concentration above or equal to 16%	± 3,0 percentage points in absolute terms
Reactivity	± 15 percentage points in absolute terms

Quantity	- 5 % relative deviation applicable to the declared value
----------	---

PFC 3: SOIL IMPROVER

Forms of the declared nutrient and other declared quality criteria	Permissible tolerances for the declared parameter
pH	± 0,7 at the time of manufacture ± 1,0 at any time in the distribution chain
Organic carbon (C)	± 10% relative deviation of the declared value up to a maximum of 1,0 percentage points in absolute terms
Total nitrogen (N)	± 20% relative deviation up to a maximum of 1,0 percentage point in absolute terms
Total phosphorus pentoxide (P ₂ O ₅)	± 20% relative deviation up to a maximum of 1,0 percentage point in absolute terms
Total potassium oxide (K ₂ O)	± 20% relative deviation up to a maximum of 1,0 percentage point in absolute terms
Dry matter	± 10% relative deviation of the declared value
Quantity	- 5% relative deviation of the declared value at the time of manufacture - 25% relative deviation of the declared value at any time in the distribution chain
Carbon (C) org /Nitrogen (N) org	± 20% relative deviation of the declared value up to a maximum of 2,0 percentage points in absolute terms
Granulometry	± 10 % relative deviation applicable to the declared percentage of material passing a specific sieve.

PFC 4: GROWING MEDIUM

Forms for the declared nutrient and other declared quality criteria	Permissible tolerances for the declared parameter
Electric conductivity	± 50% relative deviation at the time of manufacture ± 75% relative deviation at any time in the distribution chain
pH	± 0,7 at the time of manufacture ± 1,0 at any time in the distribution chain

Quantity by volume (litres or m ³)	- 5% relative deviation at the time of manufacture - 25% relative deviation at any time in the distribution chain
Quantity (volume) determination of materials with particle size greater than 60 mm	- 5% relative deviation at the time of manufacture - 25% relative deviation at any time in the distribution chain
Quantity (volume) determination of pre-shaped GM	- 5% relative deviation at the time of manufacture - 25% relative deviation at any time in the distribution chain
Water-soluble nitrogen (N)	± 50% relative deviation at the time of manufacture ± 75% relative deviation at any time in the distribution chain
Water-soluble phosphorus pentoxide (P ₂ O ₅)	± 50% relative deviation at the time of manufacture ± 75% relative deviation at any time in the distribution chain
Water-soluble potassium oxide (K ₂ O)	± 50% relative deviation at the time of manufacture ± 75% relative deviation at any time in the distribution chain

PFC 6: PLANT BIOSTIMULANT

Declared content in g/kg or g/l at 20°C	Permissible tolerance
Up to 25	± 15% relative deviation for PFC 6 ± 15% relative deviation when plant biostimulants are blended with other CE marked fertilising products under PFC 7
More than 25 up to 100	± 10% relative deviation
More than 100 up to 250	± 6% relative deviation
More than 250 up to 500	± 5% relative deviation
More than 500	± 25g/kg or ± 25g/l

ANNEX IV
Conformity assessment procedures

PART 1

APPLICABILITY OF CONFORMITY ASSESSMENT PROCEDURES

This Part sets out the applicability of conformity assessment procedure modules, as specified in Part 2 of this Annex, to CE marked fertilising products depending on their Component Material Categories as specified in Annex II ('CMC'), and their Product Function Categories as specified in Annex I ('PFC').

1. APPLICABILITY OF INTERNAL PRODUCTION CONTROL (MODULE A)

1. Module A may be used for a CE marked fertilising product composed solely of one or more
 - (a) virgin material substances or mixtures as specified in CMC 1,
 - (b) energy crop digestates as specified in CMC 4,
 - (c) food industry by-products as specified in CMC 6,
 - (d) micro-organisms as specified in CMC 7,
 - (e) agronomic additives as specified in CMC 8, or
 - (f) nutrient polymers as specified in CMC 9.
2. Module A may also be used for a fertilising product blend as specified in PFC 7.
3. By derogation from paragraphs 1 and 2, Module A must not be used for
 - (a) a straight or compound solid inorganic macronutrient ammonium nitrate fertiliser of high nitrogen content, as specified in PFC 1(C)(I)(a)(i-ii)(A), or a fertilising product blend containing such a product,
 - (b) a nitrification inhibitor as specified in PFC 5(A)(I),
 - (c) a urease inhibitor as specified in PFC 5(A)(II), or
 - (d) a plant biostimulant as specified in PFC 6.

2. APPLICABILITY OF INTERNAL PRODUCTION CONTROL PLUS SUPERVISED PRODUCT TESTING (MODULE A1)

Module A1 shall be used for a straight or compound solid inorganic macronutrient ammonium nitrate fertiliser of high nitrogen content, as specified in PFC 1(C)(I)(a)(i-ii)(A), and for a fertilising product blend as specified in PFC 7 containing such a product.

3. APPLICABILITY OF EU-TYPE EXAMINATION (MODULE B) AND CONFORMITY TO TYPE BASED ON INTERNAL PRODUCTION CONTROL (MODULE C)

1. Module B in combination with Module C may be used for a CE marked fertilising product composed solely of one or more
 - (a) non-processed or mechanically processed plant, plant parts or plant extracts as specified in CMC 2,

- (b) other polymers than nutrient polymers as specified in CMC 10,
 - (c) certain animal by-products as specified in CMC 11, or
 - (d) CMCs eligible for Module A pursuant to paragraph 1 under Heading 1 on applicability of that Module.
2. Module B and Module C may also be used for
- (a) a nitrification inhibitor as specified in PFC 5(A)(I),
 - (b) a urease inhibitor as specified in PFC 5(A)(II),
 - (c) a plant biostimulant as specified in PFC 6, and
 - (d) a product eligible for Module A pursuant to paragraph 2 under Heading 1 on applicability of that Module.
3. By derogation from paragraphs 1 and 2, Module B and Module C must not be used for a straight or compound solid inorganic macronutrient ammonium nitrate fertiliser of high nitrogen content, as specified in PFC 1(C)(I)(a)(i-ii)(A), or a fertilising product blend containing such a product.
- 4. APPLICABILITY OF QUALITY ASSURANCE OF THE PRODUCTION PROCESS (MODULE D1)**
1. Module D1 may be used for any CE marked fertilising product.
2. By derogation from paragraph 1, Module D1 must not be used for a straight or compound solid inorganic macronutrient ammonium nitrate fertiliser of high nitrogen content, as specified in PFC 1(C)(I)(a)(i-ii)(A), or a fertilising product blend containing such a product.

PART 2

DESCRIPTION OF CONFORMITY ASSESSMENT PROCEDURES

MODULE A – INTERNAL PRODUCTION CONTROL

1. Description of the module

1. Internal production control is the conformity assessment procedure whereby the manufacturer fulfils the obligations laid down under Headings 2, 3 and 4 below, and ensures and declares on his or her sole responsibility that the CE marked fertilising products concerned satisfy the requirements of this Regulation that apply to them.

2. Technical documentation

- 2.1 The manufacturer shall establish the technical documentation. The documentation shall make it possible to assess the CE marked fertilising product's conformity to the relevant requirements, and shall include an adequate analysis and assessment of the risk(s).
- 2.2 The technical documentation shall specify the applicable requirements and cover, as far as relevant for the assessment, the design, manufacture and use of the CE marked fertilising product. The technical documentation shall contain at least the following elements:
- (a) a general description of the CE marked fertilising product,
 - (b) conceptual design and manufacturing drawings and schemes,

- (c) descriptions and explanations necessary for the understanding of those drawings and schemes and the use of the CE marked fertilising product,
- (d) a list of the harmonised standards applied in full or in part the references of which have been published in the *Official Journal of the European Union* and, where those harmonised standards have not been applied, descriptions of the solutions adopted to meet the essential requirements of this Regulation, including a list of common specifications or other relevant technical specifications applied. In the event of partly applied harmonised standards, the technical documentation shall specify the parts which have been applied,
- (e) results of design calculations made, examinations carried out, *etc.*, and
- (f) test reports.

3. Manufacturing

- 3. The manufacturer shall take all measures necessary so that the manufacturing process and its monitoring ensure compliance of the manufactured CE marked fertilising products with the technical documentation referred to under Heading 2 above and with the requirements of this Regulation that apply to them.

4. CE marking, EU declaration of conformity

- 4.1. The manufacturer shall affix the CE mark to each individual fertilising product that satisfies the applicable requirements of this Regulation.
- 4.2. The manufacturer shall draw up a written EU declaration of conformity for each CE marked fertilising product lot and keep it together with the technical documentation at the disposal of the national authorities for 10 years after the CE marked fertilising product has been placed on the market. The EU declaration of conformity shall identify the CE marked fertilising product for which it has been drawn up.
- 4.3. A copy of the EU declaration of conformity shall accompany every CE marked fertilising product.

5. Authorised representative

- 5. The manufacturer's obligations set out under Heading 4 above may be fulfilled by his or her authorised representative, on his or her behalf and under his or her responsibility, provided that they are specified in the mandate.

MODULE A1 – INTERNAL PRODUCTION CONTROL PLUS SUPERVISED PRODUCT TESTING

1. Description of the module

- 1. Internal production control plus supervised product testing is the conformity assessment procedure whereby the manufacturer fulfils the obligations laid down under Headings 2, 3, 4, and 5 below, and ensures and declares on his or her sole responsibility that the CE marked fertilising products concerned satisfy the requirements of this Regulation that apply to them.

2. Technical documentation

- 2.1. The manufacturer shall establish the technical documentation. The documentation shall make it possible to assess the CE marked fertilising product's conformity with the relevant requirements, and shall include an adequate analysis and assessment of the risk(s).

- 2.2. The technical documentation shall specify the applicable requirements and cover, as far as relevant for the assessment, the design, manufacture and use of the CE marked fertilising product. The technical documentation shall contain, wherever applicable, at least the following elements:
- (a) a general description of the CE marked fertilising product,
 - (b) conceptual design and manufacturing drawings and schemes,
 - (c) descriptions and explanations necessary for the understanding of those drawings and schemes and the use of the CE marked fertilising product,
 - (d) the names and addresses of the sites, and of the operators of the sites, at which the product and its principal components were manufactured,
 - (e) a list of the harmonised standards applied in full or in part the references of which have been published in the *Official Journal of the European Union* and, where those harmonised standards have not been applied, descriptions of the solutions adopted to meet the essential requirements of this Regulation, including a list of common specifications or other relevant technical specifications applied. In the event of partly applied harmonised standards, the technical documentation shall specify the parts which have been applied,
 - (f) results of design calculations made, examinations carried out, *etc.*, and
 - (g) test reports.

3. Manufacturing

3. The manufacturer shall take all measures necessary so that the manufacturing process and its monitoring ensure compliance of the manufactured CE marked fertilising products with the technical documentation referred to under Heading 2 above and with the requirements of this Regulation.

4. Product checks for oil retention and detonation resistance

4. The cycles and test referred to under Headings 4.1-4.3 below shall be carried out on a representative sample of the product at least every 3 months on behalf of the manufacturer, in order to verify conformity with
- (a) the oil retention requirement referred to in paragraph 4 under PFC 1(C)(I)(a)(i-ii)(A) in Annex I to this Regulation, and
 - (b) the detonation resistance requirement referred to in paragraph 5 under PFC 1(C)(I)(a)(i-ii)(A) in Annex I to this Regulation.

The tests shall be carried out under the responsibility of a notified body chosen by the manufacturer.

- 4.1. *Thermal cycles prior to a test for compliance with the oil retention requirement referred to in paragraph 4 under PFC 1(C)(I)(a)(i-ii)(A) in Annex I*

4.1.1. Principle and definition

- 4.1.1. In an Erlenmeyer flask, heat the sample from ambient temperature to 50°C and maintain at this temperature for a period of two hours (phase at 50°C). Thereupon cool the sample until a temperature of 25°C is achieved and maintain at that temperature for two hours (phase at 25°C). The combination of the successive phases at 50°C and 25°C forms one thermal cycle. After being subjected to two thermal

cycles, the test sample is held at a temperature of $20 (\pm 3)^\circ\text{C}$ for the determination of the oil retention value.

4.1.2. *Apparatus*

4.1.2. Normal laboratory apparatus, in particular:

- (a) water baths thermostated at $25 (\pm 1)$ and $50 (\pm 1)^\circ\text{C}$ respectively,
- (b) Erlenmeyer flasks with an individual capacity of 150 ml.

4.1.3. *Procedure*

- 4.1.3.1. Put each test sample of $70 (\pm 5)$ grams into an Erlenmeyer flask which is then sealed with a stopper.
- 4.1.3.2. Move each flask every two hours from the 50°C bath to the 25°C bath and vice versa.
- 4.1.3.3. Maintain the water in each bath at constant temperature and keep in motion by rapid stirring to ensure the water level comes above the level of the sample. Protect the stopper from condensation by a foam rubber cap.

4.2. *Thermal cycles prior to the detonation resistance test referred to in paragraph 5 under PFC 1(C)(I)(a)(i-ii)(A) in Annex I*

4.2.1. *Principle and definition*

4.2.1. In a watertight box heat the sample from ambient temperature to 50°C and maintain at this temperature for a period of one hour (phase at 50°C). Thereupon cool the sample until a temperature of 25°C is achieved and maintain at that temperature for one hour (phase at 25°C). The combination of the successive phases at 50°C and 25°C forms one thermal cycle. After being subjected to the required number of thermal cycles, the test sample is held at a temperature of $20 (\pm 3)^\circ\text{C}$ pending the execution of the detonability test.

4.2.2. *Apparatus*

- (a) A water bath, thermostated in a temperature range of 20 to 51°C with a minimum heating and cooling rate of $10^\circ\text{C}/\text{h}$, or two water baths, one thermostated at a temperature of 20°C , the other at 51°C . The water in the bath(s) is continuously stirred; the volume of the bath shall be large enough to guarantee ample circulation of the water.
- (b) A stainless steel box, watertight all around and provided with a thermocouple in the centre. The outside width of the box is $45 (\pm 2)$ mm and the wall thickness is 1,5 mm (see Figure 1). The height and length of the box can be chosen to suit the dimensions of the water bath, e.g. length 600 mm, height 400 mm.

4.2.3. *Procedure*

4.2.3. Place a quantity of fertilisers sufficient for a single detonation into the box and close the cover. Place the box in the water bath. Heat the water to 51°C and measure the temperature in the centre of the fertiliser. One hour after the temperature at the centre has reached 50°C cool the water. One hour after the temperature at the centre has reached 25°C heat the water to start the second cycle. In the case of two water baths, transfer the box to the other bath after each heating/cooling period.

Figure 1

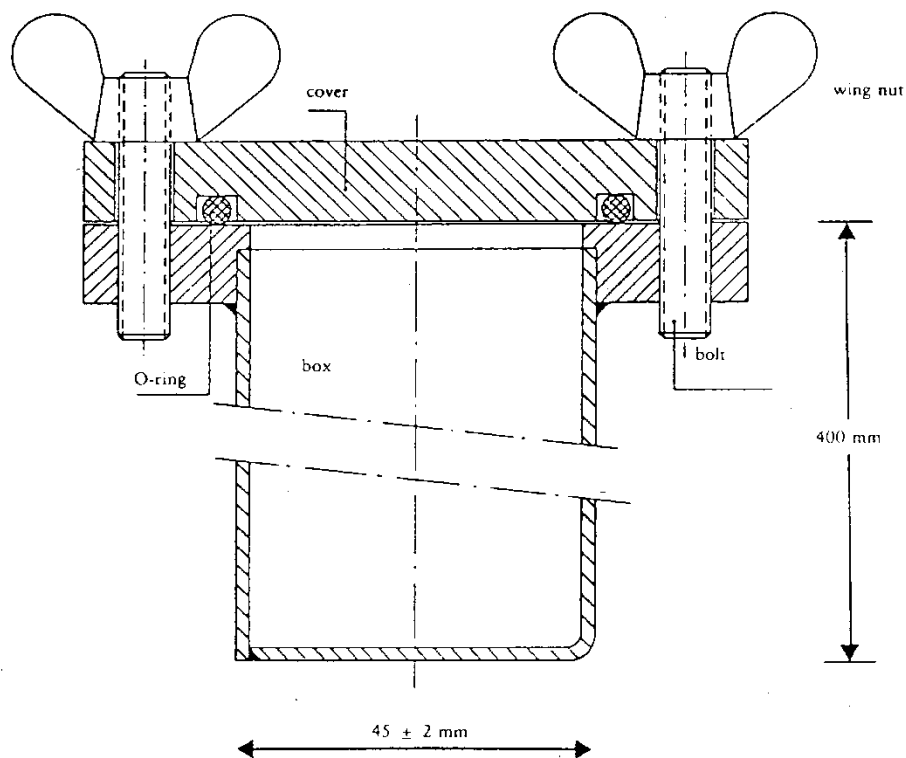

4.3. *Detonation resistance test referred to in paragraph 5 under PFC 1(C)(I)(a)(i-ii)(A) in Annex I*

4.3.1. *Description*

4.3.1.1 The test shall be carried out on a representative sample of the CE marked fertilising product. Before being tested for resistance to detonation, the whole mass of the sample is to be thermally cycled five times complying with the provisions under heading 4.2 above.

4.3.1.2. The CE marked fertilising product shall be subjected to the test of resistance to detonation in a horizontal steel tube under the following conditions:

- (a) seamless steel tube,
- (b) Tube length: 1 000 mm at least,
- (c) Nominal external diameter: 114 mm at least,
- (d) Nominal wall thickness: 5 mm at least,
- (e) Booster: the type and mass of the booster chosen shall be such as to maximise the detonation pressure applied to the sample in order to determine its susceptibility to the transmission of detonation,
- (f) Test temperature: 15-25°C,
- (g) Witness lead cylinders for detecting detonation: 50 mm diameter and 100 mm high
- (h) placed at 150 mm intervals and supporting the tube horizontally. The test is to be carried out twice. The test is deemed conclusive if in both tests one or more of the supporting lead cylinders is crushed by less than 5%.

4.3.2. Principle

4.3.2. The test sample is confined in a steel tube and subjected to detonation shock from an explosive booster charge. Propagation of the detonation is determined from the degree of crushing of lead cylinders on which the tube rests horizontally during the test.

4.3.3. Materials

- (a) Plastic explosive containing 83 to 86% penthrite
 - Density: 1 500 to 1 600 kg/m³
 - Detonation velocity: 7 300 to 7 700 m/s
 - Mass: 500 (± 1) gram.
- (b) Seven lengths of flexible detonating cord with non-metallic sleeve
 - Filling mass: 11 to 13 g/m
 - Length of each cord: 400 (± 2) mm.
- (c) Compressed pellet of secondary explosive, recessed to receive detonator
 - Explosive: hexogen/wax 95/5 or tetryl or similar secondary explosive, with or without added graphite.
 - Density: 1 500 to 1 600 kg/m³
 - Diameter: 19 to 21 mm
 - Height: 19 to 23 mm
 - Central recess to receive detonator: diameter 7 to 7,3 mm, depth 12 mm.
- (d) Seamless steel tube as specified in ISO 65 – 1981 – Heavy Series, with nominal dimensions DN 100 (4")
 - Outside diameter: 113,1 to 115,0 mm
 - Wall thickness: 5,0 to 6,5 mm
 - Length: 1 005 (± 2) mm.
- (e) Bottom plate
 - Material: steel of good weldable quality
 - Dimensions: 160 × 160 mm
 - Thickness: 5 to 6 mm.
- (f) Six lead cylinders
 - Diameter: 50 (± 1) mm
 - Height: 100 to 101 mm
 - Materials: soft lead, at least 99,5% purity.
- (g) Steel block
 - Length: at least 1 000 mm
 - Width: at least 150 mm

- Height: at least 150 mm
 - Mass: at least 300 kg if there is no firm base for the steel block.
- (h) Plastic or cardboard cylinder for booster charge
- Wall thickness: 1,5 to 2,5 mm
 - Diameter: 92 to 96 mm
 - Height: 64 to 67 mm.
- (i) Detonator (electric or non-electric) with initiation force 8 to 10
- (j) Wooden disc
- Diameter: 92 to 96 mm. Diameter to be matched to the internal diameter of the plastic or cardboard cylinder (point (h) above)
 - Thickness: 20 mm.
- (k) Wooden rod of same dimensions as detonator (point (i) above)
- (l) Dressmaking pins (maximum length 20 mm)

4.3.4. Procedure

4.3.4.1. Preparation of booster charge for insertion into steel tube

4.3.4.1. Depending on the availability of equipment, the explosive can be initiated in the booster charge either

- by seven-point simultaneous initiation as referred to under Heading 4.3.4.1.1. below, or
- by central initiation by a compressed pellet as referred to under Heading 4.3.4.1.2. below.

4.3.4.1.1. Seven-point simultaneous initiation

4.3.4.1.1. The booster charge prepared for use is shown in Figure 2 below.

4.3.4.1.1.1. Drill holes in the wooden disc (point (j) under Heading 4.3.3. above) parallel to the axis of the disc through the centre and through six points symmetrically distributed around a concentric circle 55 mm in diameter. The diameter of the holes shall be 6 to 7 mm (see Section A-B in Figure 2), depending on the diameter of the detonating cord used (point (b) under Heading 4.3.3. above).

4.3.4.1.1.2. Cut seven lengths of flexible detonating cord (point (b) under Heading 4.3.3. above) each 400 mm long, avoiding any loss of explosive at each end by making a clean cut and immediately sealing the end with adhesive. Push each of the seven lengths through each of the seven holes in the wooden disc (point (j) under Heading 4.3.3. above) until their ends project a few centimetres on the other side of the disc. Then insert a small dressmaking pin (point (l) under Heading 4.3.3. above) transversally into the textile sleeve of each length of cord 5 to 6 mm from the end and apply adhesive around the outside of the lengths of cord in a band 2 cm wide adjacent to the pin. Finally, pull the long piece of each cord to bring the pin into contact with the wooden disc.

4.3.4.1.1.3. Shape the plastic explosive (point (a) under Heading 4.3.3. above) to form a cylinder 92 to 96 mm in diameter, depending on the diameter of the cylinder (point (h) under Heading 4.3.3. above). Stand this cylinder upright on a level surface

and insert the shaped explosive. Then insert the wooden disc¹⁷ carrying the seven lengths of detonating cord into the top of the cylinder and press it down onto the explosive. Adjust the height of the cylinder (64 to 67 mm) so that its top edge does not extend beyond the level of the wood. Finally, fix the cylinder to the wooden disc for instance with staples or small nails, around its entire circumference.

4.3.4.1.1.4. Group the free ends of the seven lengths of detonating cord around the circumference of the wooden rod (point (k) under Heading 4.3.3. above) so that their ends are all level in a plane perpendicular to the rod. Secure them in a bundle around the rod by means of adhesive tape¹⁸.

4.3.4.1.2. *Central initiation by a compressed pellet*

4.3.4.1.2. The booster charge prepared for use is shown in Figure 3.

4.3.4.1.2.1. *Preparing a compressed pellet*

4.3.4.1.2.1. Taking the necessary safety precautions, place 10 grams of a secondary explosive (point (c) under Heading 4.3.3. above) in a mould with an inside diameter of 19 to 21 mm and compress to the correct shape and density. (The ratio of diameter: height should be roughly 1:1). In the centre of the bottom of the mould there is a peg, 12 mm in height and 7,0 to 7,3 mm in diameter (depending on the diameter of the detonator used), which forms a cylindrical recess in the compressed cartridge for subsequent insertion of the detonator.

4.3.4.1.2.2. *Preparing the booster charge*

4.3.4.1.2.2. Place the explosive (point (a) under Heading 4.3.3. above) into the cylinder (point (h) under Heading 4.3.3. above) standing upright on a level surface, then press it down with a wooden die to give the explosive a cylindrical shape with a central recess. Insert the compressed pellet into this recess. Cover the cylindrically shaped explosive containing the compressed pellet with a wooden disc (point (j) under Heading 4.3.3. above) having a central hole 7,0 to 7,3 mm in diameter for insertion of a detonator. Fix the wooden disc and the cylinder together with a cross of adhesive tape. Ensure that the hole drilled in the disc and the recess in the compressed pellet are coaxial by inserting the wooden rod (point (k) under Heading 4.3.3. above).

4.3.4.2. *Preparing steel tubes for the detonation tests*

4.3.4.2. At one end of the steel tube (point (d) under Heading 4.3.3. above), drill two diametrically opposed holes 4 mm in diameter perpendicularly through the side wall at a distance of 4 mm from the edge. Butt weld the bottom plate (point (e) under Heading 4.3.3. above) to the opposite end of the tube, completely filling the right angle between the bottom plate and the wall of the tube with weld metal around the entire circumference of the tube.

4.3.4.3. *Filling and charging the steel tube*

4.3.4.3. See Figures 2 and 3.

4.3.4.3.1. The test sample, the steel tube and the booster charge shall be conditioned to temperatures of 20 (\pm 5)°C. 16 to 18 kg of the test sample are needed for two detonation tests.

¹⁷ The diameter of the disc must always correspond to the inside diameter of the cylinder.

¹⁸ NB: When the six peripheral lengths of cord are taut after assembly, the central cord must remain slightly slack.

4.3.4.3.2.1 Place the tube upright with its square bottom place resting on a firm, flat surface, preferably concrete. Fill the tube to about one-third of its height with the test sample and drop it 10 cm vertically onto the floor five times to compact the prills or granules as densely as possible in the tube. To accelerate compaction, vibrate the tube by striking the side wall with a 750 to 1 000-gram hammer between drops for a total of 10 times.

4.3.4.3.2.2. Repeat this charging method with another portion of the test sample. Finally, a further addition shall be made such that, after compaction by raising and dropping the tube 10 times and a total of 20 intermittent hammer blows, the charge fills the tube to a distance of 70 mm from its orifice.

4.3.4.3.2.3 The filling height of the sample shall be adjusted in the steel tube so that the booster charge (referred to above under Heading 4.3.4.1.1. or 4.3.4.1.2.) to be inserted later will be in close contact with the sample over its entire surface.

4.3.4.3.3. Insert the booster charge into the tube so that it is in contact with the sample; the top surface of the wooden disc shall be 6 mm below the end of the tube. Ensure essential close contact between explosive and test sample by adding or removing small quantities of sample. As shown in Figures 2 and 3, split pins should be inserted through the holes near the open end of the tube and their legs opened flat against the tube.

4.3.4.4. *Positioning of the steel tube and lead cylinders (see figure 4)*

4.3.4.4.1. Number the bases of the lead cylinders (point (f) under Heading 4.3.3. above) 1 to 6. Make six marks 150 mm apart on the centre line of a steel block (4.3.7) lying on a horizontal base, with the first mark at least 75 mm from the edge of the block. Place a lead cylinder upright on each of these marks, with the base of each cylinder centred on its mark.

4.3.4.4.2. Lay the steel tube prepared according to 4.3.4.3. horizontally on the lead cylinders so that the axis of the tube is parallel to the centre line of the steel block and the welded end of the tube extends 50 mm beyond lead cylinder No 6. To prevent the tube from rolling, insert small wooden wedges between the tops of the lead cylinders and the tube wall (one on each side) or place a cross of wood between the tube and the steel block.

Note: Make sure that the tube is in contact with all six lead cylinders; a slight curvature of the tube surface can be compensated for by rotating the tube about its longitudinal axis; if any of the lead cylinders is too tall, tap the cylinder in question carefully with a hammer until it is the required height.

4.3.4.5. *Preparation for detonation*

4.3.4.5.1. Set up the apparatus as described under Heading 4.3.4.4. in a bunker or suitably prepared underground site (e.g. mine or tunnel). Ensure that the temperature of the steel tube is kept at 20 (\pm 5)°C before detonation.

Note: Should such firing sites not be available, the work can, if necessary, be done in a concrete-lined pit covered over with wooden beams. Detonation can cause steel fragments to be projected with high kinetic energy, therefore, firing shall be carried out at a suitable distance from dwellings or thoroughfares.

4.3.4.5.2. If the booster charge with seven-point initiation is used, ensure that the detonation cords are stretched out as described in the footnote to paragraph 4.3.4.1.1.4 above and arranged as horizontally as possible.

4.3.4.5.3. Finally, remove the wooden rod and replace with the detonator. Do not carry out firing until the danger zone has been evacuated and the test personnel have taken cover.

4.3.4.5.4. Detonate the explosive.

4.3.4.6.1 Allow sufficient time for the fumes (gaseous and sometimes toxic decomposition products such as nitrous gases) to disperse, then collect the lead cylinders and measure their heights with a Vernier caliper

4.3.4.6.2. Record for each of the marked lead cylinders, the degree of crushing expressed as a percentage of the original height of 100 mm. If the cylinders are crushed obliquely, record the highest and the lowest values and calculate the average.

4.3.4.7. A probe for continuous measurement of the detonation velocity can be used; the probe should be inserted longitudinally to the axis of the tube or along its side wall.

4.3.4.8. Two detonation tests per sample are to be carried out.

4.3.5. *Test report*

4.3.5. Values for the following parameters are to be given in the test report for each of the detonation tests:

- the values actually measures for the outside diameter of the steel tube and for the wall thickness,
- the Brinell hardness of the steel tube,
- the temperature of the tube and the sample shortly before firing,
- the packing density (kg/m^3) of the sample in the steel tube,
- the height of each lead cylinder after firing, specifying the corresponding cylinder number,
- method of initiation employed for the booster charge.

4.3.5.1. *Evaluation of test results*

4.3.5.1. If, in each firing, the crushing of at least one lead cylinder is less than 5%, the test shall be considered conclusive.

Figure 2

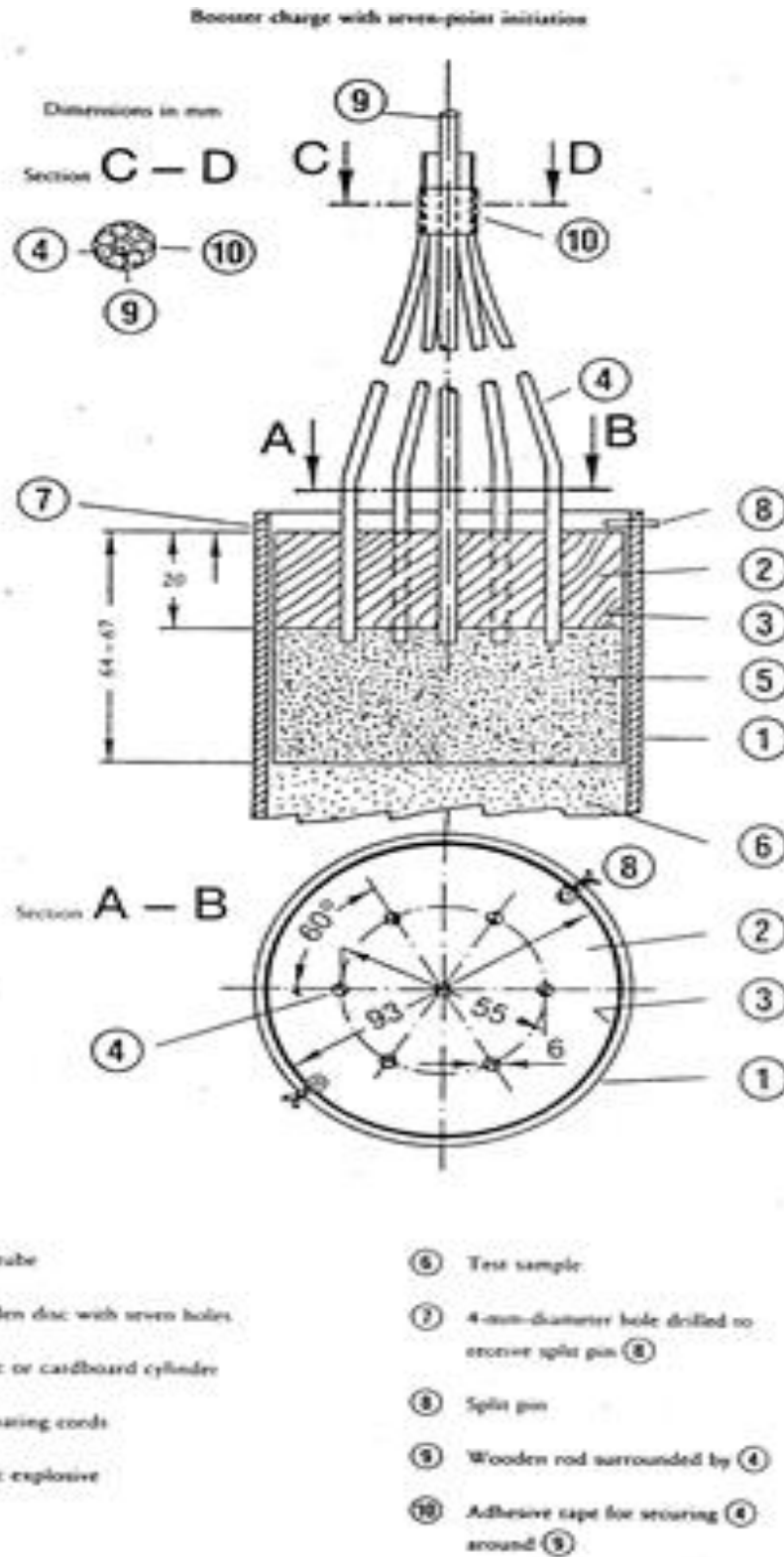

Figure 3

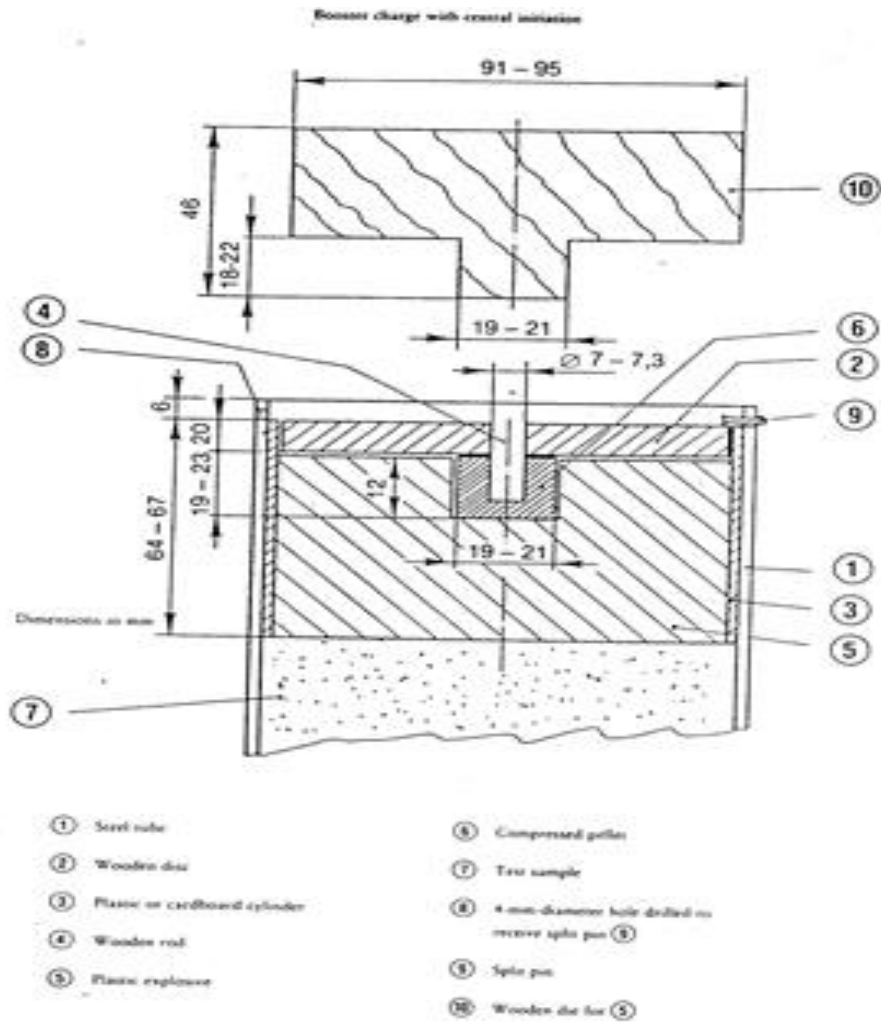
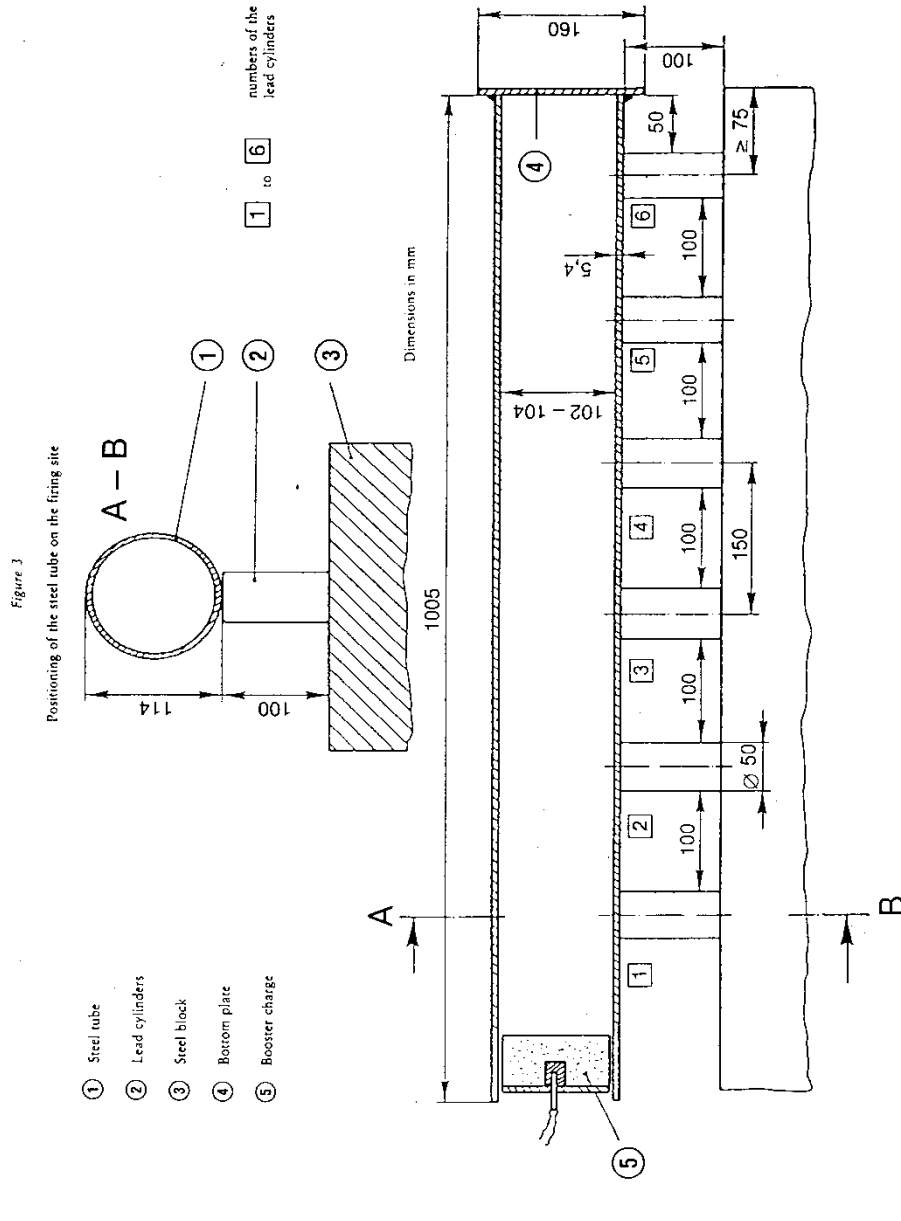

Figure 4



5. Conformity marking and EU declaration of conformity

- 5.1. The manufacturer shall affix the CE mark to each individual fertilising product that satisfies the applicable requirements of this Regulation.
- 5.2. The manufacturer shall draw up a written EU declaration of conformity for each CE marked fertilising product lot and keep it together with the technical documentation at the disposal of the national authorities for 10 years after the CE marked fertilising product has been placed on the market. The EU declaration of conformity shall identify such CE marked fertilising product for which it has been drawn up.

6. Authorised representative

6. The manufacturer's obligations set out under Heading 5 above may be fulfilled by his or her authorised representative, on his or her behalf and under his or her responsibility, provided that they are specified in the mandate.

MODULE B – EU-TYPE EXAMINATION

1. EU-type examination is the part of a conformity assessment procedure in which a notified body examines the technical design of a CE marked fertilising product and verifies and attests that the technical design of the CE marked fertilising product meets the requirements of this Regulation.
2. Assessment of the adequacy of the technical design of the CE marked fertilising product may be carried out through examination of the technical documentation and supporting evidence referred to in paragraph 3.2 below, plus examination of specimens, representative of the production envisaged, of one or more critical components of the product (combination of production type and design type).
 - 3.1. The manufacturer shall lodge an application for EU-type examination with a single notified body of his or her choice.
 - 3.2. The application shall include:
 - (a) the name and address of the manufacturer and, if the application is lodged by the authorised representative, his or her name and address as well,
 - (b) a written declaration that the same application has not been lodged with any other notified body,
 - (c) the technical documentation. The technical documentation shall make it possible to assess the CE marked fertilising product's conformity with the applicable requirements of this Regulation and shall include an adequate analysis and assessment of the risk(s). The technical documentation shall specify the applicable requirements and cover, as far as relevant for the assessment, the design, manufacture and use of the CE marked fertilising product. The technical documentation shall contain, wherever applicable, at least the following elements:
 - a general description of the CE marked fertilising product,
 - conceptual design and manufacturing drawings and schemes
 - descriptions and explanations necessary for the understanding of those drawings and schemes and the use of the CE marked fertilising product,
 - a list of the harmonised standards applied in full or in part the references of which have been published in the *Official Journal of the European Union* and, where those harmonised standards have not been applied, descriptions of the solutions adopted to meet the essential requirements of this Regulation, including a list of common specifications or other relevant technical specifications applied. In the event of partly applied harmonised standards, the technical documentation shall specify the parts which have been applied,
 - results of design calculations made, examinations carried out, *etc.*,
 - test reports, and

- where the product contains or consists of animal by-products within the meaning of Regulation (EC) No 1069/2009, the commercial documents or health certificates required pursuant to that Regulation, and evidence that the animal by-products have reached the end point in the manufacturing chain within the meaning of that Regulation;
- (d) the specimens representative of the production envisaged. The notified body may request further specimens if needed for carrying out the test programme;
 - (e) the supporting evidence for the adequacy of the technical design solution. This supporting evidence shall mention any documents that have been used, in particular where the relevant harmonised standards have not been applied in full. The supporting evidence shall include, where necessary, the results of tests carried out in accordance with other relevant technical specifications by the appropriate laboratory of the manufacturer, or by another testing laboratory on his or her behalf and under his or her responsibility.
4. The notified body shall:
- (a) For the CE marked fertilising product:
 - (1) examine the technical documentation and supporting evidence to assess the adequacy of the technical design of the CE marked fertilising product;
 - (b) For the specimen(s):
 - (2) verify that the specimen(s) have been manufactured in conformity with the technical documentation, and identify the elements which have been designed in accordance with the applicable provisions of the relevant harmonised standards and/or technical specifications, as well as the elements which have been designed in accordance with other relevant technical specifications;
 - (3) carry out appropriate examinations and tests, or have them carried out, to check whether, where the manufacturer has chosen to apply the solutions in the relevant harmonised standards and/or technical specifications, these have been applied correctly;
 - (4) carry out appropriate examinations and tests, or have them carried out, to check whether, where the solutions in the relevant harmonised standards and/or technical specifications have not been applied, the solutions adopted by the manufacturer meet the corresponding essential requirements of this Regulation;
 - (5) agree with the manufacturer on a location where the examinations and tests will be carried out.
5. The notified body shall draw up an evaluation report that records the activities undertaken in accordance with point 4 and their outcomes. Without prejudice to its obligations *vis-à-vis* the notifying authorities, the notified body shall release the content of that report, in full or in part, only with the agreement of the manufacturer.
- 6.1. Where the type meets the requirements of this Regulation that apply to the CE marked fertilising product concerned, the notified body shall issue an EU-type examination certificate to the manufacturer. The certificate shall contain the name and address of the manufacturer, the conclusions of the examination, the conditions

(if any) for its validity and the necessary data for identification of the approved type. The certificate may have one or more annexes attached.

- 6.2. The certificate and its annexes shall contain all relevant information to allow the conformity of manufactured CE marked fertilising products with the examined type to be evaluated and to allow for further in-service control.
- 6.3. Where the type does not satisfy the requirements of this Regulation, the notified body shall refuse to issue an EU-type examination certificate and shall inform the applicant accordingly, giving detailed reasons for its refusal.
- 7.1. The notified body shall keep itself apprised of any changes in the generally acknowledged state of the art which indicate that the approved type may no longer comply with the requirements of this Regulation and shall determine whether such changes require further investigation. If so, the notified body shall inform the manufacturer accordingly.
- 7.2. The manufacturer shall inform the notified body that holds the technical documentation relating to the EU-type examination certificate of all modifications to the approved type that may affect the conformity of the CE marked fertilising product with the requirements of this Regulation or the conditions for validity of the certificate. Such modifications shall require additional approval in the form of an addition to the original EU-type examination certificate.
- 8.1. Each notified body shall inform its notifying authority concerning the EU-type examination certificates and/or any additions thereto which it has issued or withdrawn, and shall, periodically or upon request, make available to its notifying authorities the list of certificates and/or any additions thereto refused, suspended or otherwise restricted.
- 8.2. Each notified body shall inform the other notified bodies concerning the EU-type examination certificates and/or any additions thereto which it has refused, withdrawn, suspended or otherwise restricted, and, upon request, concerning the certificates and/or additions thereto which it has issued.
- 8.3. The Commission, the Member States and the other notified bodies may, on request, obtain a copy of the EU-type examination certificates and/or additions thereto. On request, the Commission and the Member States may obtain a copy of the technical documentation and the results of the examinations carried out by the notified body.
- 8.4. The notified body shall keep a copy of the EU-type examination certificate, its annexes and additions, as well as the technical file including the documentation submitted by the manufacturer, until the expiry of the validity of the certificate.
9. The manufacturer shall keep a copy of the EU-type examination certificate, its annexes and additions together with the technical documentation at the disposal of the national authorities for 10 years after the CE marked fertilising product has been placed on the market.
10. The manufacturer's authorised representative may lodge the application referred to in point 3 and fulfil the obligations set out in points 7 and 9, provided that they are specified in the mandate.

MODULE C – CONFORMITY TO TYPE BASED ON INTERNAL PRODUCTION CONTROL

1. Description of the module

1. Conformity to type based on internal production control is the part of a conformity assessment procedure whereby the manufacturer fulfils the obligations laid down in points 2 and 3, and ensures and declares that the CE marked fertilising products concerned are in conformity with the type described in the EU-type examination certificate and satisfy the requirements of this Regulation that apply to them.

2. Manufacturing

2. The manufacturer shall take all measures necessary so that the manufacturing process and its monitoring ensure conformity of the manufactured CE marked fertilising products with the approved type described in the EU-type examination certificate and with the requirements of this Regulation that apply to them.

3. Conformity marking and EU declaration of conformity

- 3.1 The manufacturer shall affix the CE marking to each individual fertilising product that is in conformity with the type described in the EU-type examination certificate and satisfies the requirements of this Regulation.
- 3.2 The manufacturer shall draw up a written EU declaration of conformity for a CE marked fertilising product lot and keep it at the disposal of the national authorities for 10 years after the CE marked fertilising product has been placed on the market. The EU declaration of conformity shall identify the CE marked fertilising product lot for which it has been drawn up.
- 3.3. A copy of the EU declaration of conformity shall be made available to the relevant authorities upon request.

4. Authorised representative

4. The manufacturer's obligations set out in point 3 may be fulfilled by his or her authorised representative, on his or her behalf and under his or her responsibility, provided that they are specified in the mandate.

MODULE D1: QUALITY ASSURANCE OF THE PRODUCTION PROCESS

1. Description of the module

1. Quality assurance of the production process is the conformity assessment procedure whereby the manufacturer of the CE marked fertilising product fulfils the obligations laid down under Headings 2, 4, and 7, and ensures and declares on his or her sole responsibility that the CE marked fertilising products concerned satisfy the requirements of this Regulation that apply to them.

2. Technical documentation

2. The manufacturer of the CE marked fertilising product shall establish the technical documentation. The documentation shall make it possible to assess the product's conformity with the relevant requirements, and shall include an adequate analysis and assessment of the risk(s). The technical documentation shall specify the applicable requirements and cover, as far as relevant for the assessment, the design, manufacture and use of the product. The technical documentation shall, wherever applicable, contain at least the following elements:

- (a) a general description of the product,

- (b) conceptual design and manufacturing drawings and schemes, including a written description and a diagram of the production process, where each treatment, storage vessel and area is clearly identified,
- (c) descriptions and explanations necessary for the understanding of those drawings and schemes and of the use of the CE marked fertilising product,
- (d) a list of the harmonised standards applied in full or in part the references of which have been published in the *Official Journal of the European Union* and, where those harmonised standards have not been applied, descriptions of the solutions adopted to meet the essential requirements of this Regulation, including a list of common specifications or other relevant technical specifications applied. In the event of partly applied harmonised standards, the technical documentation shall specify the parts which have been applied,
- (e) results of design calculations made, examinations carried out, *etc.*,
- (f) test reports, and
- (g) where the product contains or consists of animal by-products within the meaning of Regulation (EC) No 1069/2009, the commercial documents or health certificates required pursuant to that Regulation, and evidence that the animal by-products have reached the end point in the manufacturing chain within the meaning of that Regulation.

3. Availability of technical documentation

- 3. The manufacturer shall keep the technical documentation at the disposal of the relevant national authorities for 10 years after the CE marked fertilising product has been placed on the market.

4. Manufacturing

- 4. The manufacturer shall operate an approved quality system for production, final product inspection and testing of the products concerned as specified in point 5, and shall be subject to surveillance as specified in point 6.

5. Quality system

- 5.1. The manufacturer shall implement a quality system which shall ensure compliance of the CE marked fertilising product with the requirements of this Regulation that apply to them.
 - 5.1.1. The quality system shall include quality objectives and an organisational structure with responsibilities and powers of the management with regard to product quality.
 - 5.1.1.1. For compost belonging to component material category ('CMC') 3 and digestate belonging to CMC 5, as defined in Annex II, senior management of the manufacturer's organisation shall:
 - (a) Ensure that sufficient resources (people, infrastructure, equipment) are available to create and implement the quality system;
 - (b) Appoint a member of the organisation's management who shall be responsible for:
 - Ensuring that quality management processes are established, approved, implemented and maintained;

- Reporting to senior management of the manufacturer on the performance of the quality management and any need for improvement;
 - Ensuring the promotion of awareness of customer needs and legal requirements throughout the manufacturer's organisation, and for making the personnel aware of the relevance and importance of the quality management requirements to meet the legal requirements of this Regulation;
 - Ensuring that each person whose duties affect the product quality is sufficiently trained and instructed; and
 - Ensuring the classification of the quality management documents mentioned under paragraph 5.1.4. below;
- (c) Conduct an internal audit every year, or sooner than scheduled if triggered by any significant change that may affect the quality of the CE marked fertilising product; and
- (d) Ensure that appropriate communication processes are established within and outside the organisation and that communication take place regarding the effectiveness of the quality management.
- 5.1.2. The quality system shall be implemented through manufacturing, quality control and quality assurance techniques, processes and systematic actions.
- 5.1.2.1. For compost belonging to component material category ('CMC') 3 and digestate belonging to CMC 5, as defined in Annex II, the system shall ensure compliance with the composting and digestion process criteria specified in that Annex.
- 5.1.3. The quality system shall comprise examinations and tests to be carried out before, during and after manufacture with a specified frequency.
- 5.1.3.1. For compost belonging to CMC 3 and digestate belonging to CMC 5, as defined in Annex II, the examinations and tests shall comprise the following elements:
- (a) The following information shall be recorded for each lot of input materials:
- (1) Date delivered;
 - (2) Amount by weight (or estimation based on the volume and density);
 - (3) Identity of the input material supplier;
 - (4) Input material type;
 - (5) Identification of each lot and delivery location on site. A unique identification code shall be assigned throughout the production process for quality management purposes; and
 - (6) In case of refusal, the reasons for the rejection of the lot and where it was sent.
- (b) Qualified staff shall carry out a visual inspection of each consignment of input materials and verify compatibility with the specifications of input materials in CMC 3 and CMC 5 in Annex II.

- (c) The manufacturer shall refuse any consignment of any given input material where visual inspection raises any suspicion of
- the presence of hazardous or damageable substances for the composting or digestion process or for the quality of the final CE marked fertilising product, or of
 - incompatibility with the specifications of CMC 3 and CMC 5 in Annex II, in particular by presence of plastics leading to exceedence of the limit value for macroscopic impurities.
- (d) The staff shall be trained on
- potential hazardous properties that may be associated with input materials, and
 - features that allow hazardous properties and the presence of plastics to be recognised.
- (e) Samples shall be taken on output materials, to verify that they comply with the component material specifications for compost and digestate laid down in CMC 3 and CMC 5 in Annex II, and that the properties of the output material does not jeopardise the CE marked fertilising product's compliance with the relevant requirements in Annex I.
- (f) The output material samples shall be taken with at least the following frequency:

Annual input (tonnes)	Samples / year
≤ 3000	1
3001 – 10000	2
10001 – 20000	3
20001 – 40000	4
40001 – 60000	5
60001 – 80000	6
80001 – 100000	7
100001 – 120000	8
120001 – 140000	9
140001 – 160000	10
160001 – 180000	11
> 180000	12

- (g) If any tested output material sample fails one or more of the applicable limits specified in the relevant sections of Annexes I and II to this Regulation, the

person responsible for quality management referred to above in point 5.1.1.1(b) shall:

- (1) Clearly identify the non-conforming products and their storage place,
- (2) Analyse the reasons of the non-conformity and take any necessary action to avoid its repetition,
- (3) Record in the quality records referred to in paragraph 5.1.4 if reprocessing takes place, or if the product is eliminated.

5.1.4. The manufacturer shall maintain the quality records, such as inspection reports and test data, calibration data, qualification reports on the personnel concerned, etc.,

5.1.4.1. For compost belonging to component material category ('CMC') 3 and digestate belonging to CMC 5, as defined in Annex II, the quality records shall demonstrate effective control of input materials, production, storage and compliance of input- and output materials with the relevant requirements of this Regulation. Each document shall be legible and available at its relevant place(s) of use, and any obsolete version shall be promptly removed from all places where it is used, or at least identified as obsolete. The quality management documentation shall at least contain the following information:

- (a) A title,
- (b) A version number,
- (c) A date of issue,
- (d) The name of the person who issued it,
- (e) Records about the effective control of input materials,
- (f) Records about the effective control of the production process,
- (g) Records about the effective control of the output materials,
- (h) Records of non-conformities,
- (i) Reports on all accidents and incidents that occur to the site, their known or suspected causes and actions taken,
- (j) Records of the complaints expressed by third parties and how they have been addressed,
- (k) A record of the date, type and topic of training followed by the persons responsible for the quality of the product,
- (l) Results of internal audit and actions taken, and
- (m) Results of external audit review and actions taken.

5.1.5 The achievement of the required product quality and the effective operation of the quality system shall be monitored.

5.1.5.1. For compost belonging to component material category ('CMC') 3 and digestate belonging to CMC 5, as defined in Annex II, the manufacturer shall establish an annual internal audit program in order to verify the compliance to the quality system, with the following components:

- (1) A procedure that defines the responsibilities and requirements for planning and conducting internal audits, establishing records and reporting results shall be

established and documented. A report identifying the non-conformities to the quality scheme shall be prepared and all corrective actions shall be reported. The records of the internal audit shall be annexed to the quality management documentation.

- (2) Priority shall be given to non-conformities identified by external audits.
- (3) Each auditor shall not audit his or her own work.
- (4) The management responsible for the area audited shall ensure that the necessary corrective actions are taken without undue delay.
- (5) Internal audit realised in the frame of another quality management system can be taken into account provided that it is completed by an audit of the requirements to this quality system.

5.2. The manufacturer shall lodge an application for assessment of his or her quality system with the accredited notified body of his or her choice, for the products concerned. The application shall include:

- the name and address of the manufacturer and, if the application is lodged by the authorised representative, his or her name and address as well,
- a written declaration that the same application has not been lodged with any other notified body,
- all relevant information for the product category envisaged,
- the documentation concerning the quality system,
- technical documentation of all the quality system elements set out in paragraphs 5.1 and subparagraphs.

5.3. All the elements, requirements and provisions adopted by the manufacturer shall be documented in a systematic and orderly manner in the form of written policies, procedures and instructions. The quality system documentation shall permit a consistent interpretation of the quality programmes, plans, manuals and records. It shall, in particular, contain an adequate description of all the quality management elements mentioned above in paragraph 5.1 and subparagraphs.

5.4.1. The notified body shall assess the quality system to determine whether it satisfies the requirements referred to in paragraph 5.1 and subparagraphs.

5.4.2. It shall presume conformity with those requirements in respect of the elements of the quality system that comply with the corresponding specifications of the relevant harmonised standard.

5.4.3. In addition to experience in quality management systems, the auditing team shall have at least one member with experience of evaluation in the relevant product field and product technology concerned, and knowledge of the applicable requirements of this Regulation. The audit shall include an assessment visit to the manufacturer's premises. The auditing team shall review the technical documentation referred to in point 2 in order to verify the manufacturer's ability to identify the relevant requirements of this Regulation and to carry out the necessary examinations with a view to ensuring compliance of the CE marked fertilising product with those requirements.

5.4.4. The decision shall be notified to the manufacturer. The notification shall contain the conclusions of the audit and the reasoned assessment decision.

- 5.5. The manufacturer shall undertake to fulfil the obligations arising out of the quality system as approved and to maintain it so that it remains adequate and efficient
- 5.6.1. The manufacturer shall keep the notified body that has approved the quality system informed of any intended change to the quality system.
- 5.6.2. The notified body shall evaluate any proposed changes and decide whether the modified quality system will continue to satisfy the requirements referred to in point 5.2 or whether reassessment is necessary.
- 5.6.3. It shall notify the manufacturer of its decision. The notification shall contain the conclusions of the examination and the reasoned assessment decision.

6. Surveillance under the responsibility of the notified body

- 6.1 The purpose of surveillance is to make sure that the manufacturer duly fulfils the obligations arising out of the approved quality system.
- 6.2. The manufacturer shall, for assessment purposes, allow the notified body access to the manufacture, inspection, testing and storage sites and shall provide it with all necessary information, in particular:
- the quality system documentation,
 - the technical documentation referred to in paragraph 2,
 - the quality records, such as inspection reports and test data, calibration data, qualification reports on the personnel concerned.
- 6.3.1 The notified body shall carry out periodic audits to make sure that the manufacturer maintains and applies the quality system and shall provide the manufacturer with an audit report.
- 6.3.2 For compost belonging to component material category ('CMC') 3 and digestate belonging to CMC 5, as defined in Annex II, the notified body shall take and analyse output material samples during each audit, and the audits shall be carried out with the following frequency:
- (a) During the notified body's first year of surveillance of the plant in question: The same frequency as the sampling frequency indicated in the table included in paragraph 5.1.3.1(f); and
 - (b) During the following years of surveillance: Half the sampling frequency indicated in the table included in paragraph 5.1.3.1(f).
- 6.4 In addition, the notified body may pay unexpected visits to the manufacturer. During such visits the notified body may, if necessary, carry out product tests, or have them carried out, in order to verify that the quality system is functioning correctly. The notified body shall provide the manufacturer with a visit report and, if tests have been carried out, with a test report.

7. Conformity marking and EU declaration of conformity

- 7.1. The manufacturer shall affix the CE marking and, under the responsibility of the notified body referred to in paragraph 5.2, the latter's identification number to each individual product that satisfies the applicable requirements of this Regulation.
- 7.2.1 The manufacturer shall draw up a written EU declaration of conformity for each CE marked fertilising product lot and keep it at the disposal of the national authorities for 10 years after the CE marked fertilising product has been placed on the market.

The EU declaration of conformity shall identify the product lot for which it has been drawn up.

- 7.2.2. A copy of the EU declaration of conformity shall be made available to the relevant authorities upon request.

8. Availability of quality system documentation

8. The manufacturer shall, for a period ending at least 10 years after the product has been placed on the market, keep at the disposal of the national authorities:

- the documentation referred to in paragraph 5.3,
- the change referred to in paragraph 5.6 and subparagraphs, as approved,
- the decisions and reports of the notified body referred to in paragraph 5.6.1-5.6.3, paragraph 6.3 and paragraph 6.4.

9. Notified bodies' information obligation

- 9.1. Each notified body shall inform its notifying authorities of quality system approvals issued or withdrawn, and shall, periodically or upon request, make available to its notifying authorities the list of quality system approvals refused, suspended or otherwise restricted.

- 9.2. Each notified body shall inform the other notified bodies of quality system approvals which it has refused, suspended or withdrawn, and, upon request, of quality system approvals which it has issued.

10. Authorised representative

The manufacturer's obligations set out in paragraph 3, paragraph 5.2, paragraphs 5.6.1-5.6.3, Heading 7 and Heading 8 may be fulfilled by his or her authorised representative, on his or her behalf and under his or her responsibility, provided that they are specified in the mandate.

ANNEX V
EU Declaration of conformity (No XXX)¹⁹

1. CE marked fertilising product (product-, batch-, type- or serial- number):
2. Name and address of the manufacturer and, where applicable, its authorised representative:
3. This EU declaration of conformity is issued under the sole responsibility of the manufacturer.
4. Object of the declaration (identification of product allowing traceability; it may, where necessary for the identification of the CE marked fertilising product, include an image):
5. The object of the declaration described above is in conformity with the relevant Union harmonisation legislation:
6. References to the relevant harmonised standards used or references to the other technical specifications in relation to which conformity is declared:
7. Where applicable, the notified body ... (name, number) performed ... (description of intervention) and issued the certificate:
8. Additional information:

Signed for and on behalf of:

(place and date of issue):

(name, function) (signature):

¹⁹ It is optional for the manufacturer to assign a number to the EU declaration of conformity.