



DRAFT EAST AFRICAN STANDARD

Fertilizer – Methods of sampling

EAST AFRICAN COMMUNITY

Foreword

Development of the East African Standards has been necessitated by the need for harmonizing requirements governing quality of products and services in the East African Community. It is envisaged that through harmonized standardization, trade barriers that are encountered when goods and services are exchanged within the Community will be removed.

In order to achieve this objective, the Community established an East African Standards Committee mandated to develop and issue East African Standards.

The Committee is composed of representatives of the National Standards Bodies in Partner States, together with the representatives from the private sectors and consumer organizations. Draft East African Standards are circulated to stakeholders through the National Standards Bodies in the Partner States. The comments received are discussed and incorporated before finalization of standards, in accordance with the procedures of the Community.

East African Standards are subject to review, to keep pace with technological advances. Users of the East African Standards are therefore expected to ensure that they always have the latest versions of the standards they are implementing.

DRAFT FOR COMMENT ONLY

Fertilizer – Methods of sampling

1 Scope

This Draft East African Standard specifies method of drawing test samples from bags, as well as drawing samples of bulk material from wagon, truck loads or from flowing streams and from transfer belts.

2 Normative References

The following referenced documents are indispensable for the application of this standard. For dated references, only the edition cited applies. For undated references, the latest edition of the referenced document (including any amendments) applies;

ISO 8157, *Fertilizer and Soil Conditioners — Vocabulary*

3 Terms and Definition

For the purpose of this East African standard, the following terms and definition shall apply together with those given in ISO 8157;

3.1

Sample

A small representative quantity of fertilizer, normally taken for the intention of testing or analyzing the quality, particle size, nature of the whole specimen

3.2

Sampling

The act or process of selecting a sample for testing, analyzing, etc.

2.3

Lot

A definitive quantity of a fertilizer produced/taken essentially under the same conditions

2.4

Batch

A quantity or consignment of fertilizer produced at one time

4 General requirements for sampling from solid fertilizers

4.1 In drawing samples, the following precautions and directions shall be observed.

4.1.1 Samples shall be taken from the place of storage, and the process of sampling shall not be exposed to weather. The sampling equipment shall be clean, dry and should not be a source of contamination. The material being sampled, the sampling equipment and the containers for samples shall be protected from adventitious contamination. Metallic containers must be avoided. The sample immediately after being drawn shall be placed in wide-mouthed clean, dry and airtight glass or other suitable containers, for example Poly Vinyl Chloride (PVC) or polyethylene, which must not react with fertilizer.

4.1.2 The sample containers shall be of such size that they are almost completely filled by the sample (but not tightly packed). Each sample container shall be sealed air-tight filling and accompanied (marked) with full details of sampling inclusive of the following: -

- a) Name and address of the fertilizer dealer;
- b) The date of sampling;
- c) Name of fertilizer;
- d) The physical condition of the products;
- e) Name of the person who takes sample;
- f) Batch number; and
- g) Remarks.

4.2 Sample shall be stored in shade under dry weather conditions and immediately taken to laboratory for analysis

5 Sampling

5.1 Sampling from bagged fertilizers

5.1.1 Apparatus

Slotted single tube probe – Solid cone tip constructed of stainless steel or brass. The length of the probe, exclusive of handle, should approximately be equal to the diagonal of bag to be sampled. As fertilizers are normally marketed in 50 kg bags; an overall length of 110 cm would be adequate for fertilizers of low bulk density. A slot length of 105 cm and a width of 1.5 cm would be appropriate. The inside diameter of the probe should be 1.5 cm minimum. The probe is as shown in figure 1 below.

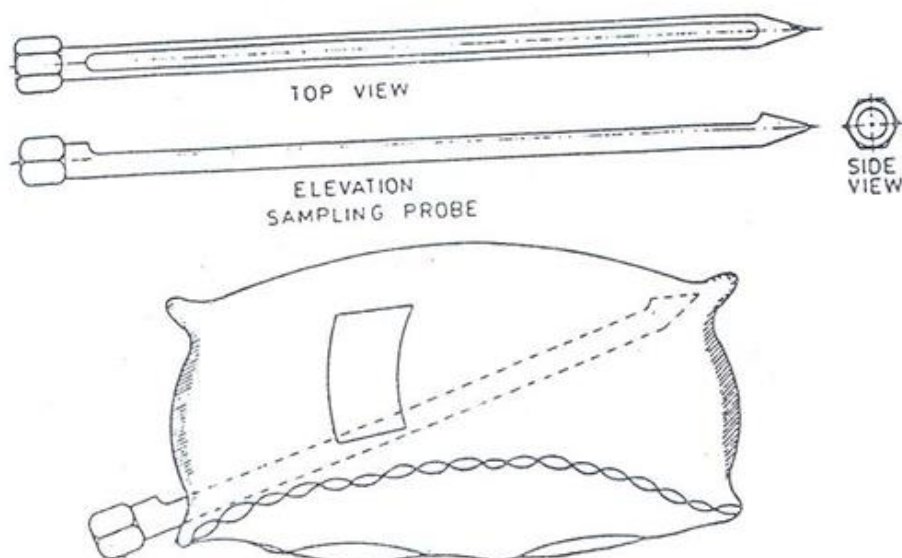

Figure 1 – Slotted single tube probe

5.1.2 Procedure

5.1.2.1 Place the bag in horizontal position, then roll or flip over three or more times.

5.1.2.2 Open the bag by cutting a couple of stitches at one corner. Insert the probe so that it extends diagonally from corner to corner (see figure 1) with slot down. It should not pierce through the bag. Turn it one half to bring the slot up, jar bag slightly to fill the probe, and remove carefully not to drag material out of it with bag edges.

5.1.2.3 Empty entire contents of each probe into a suitable container. Take one core per bag. Combine contents of all probes of the lot being sampled and place in a container with moisture seal. Label the contents before another lot is sampled.

5.1.2.4 In case the material in bag is found to be in cake condition, the bag is dropped several times from a height of 1 metre till lumps are all broken up before sampling with the probe. Mild strokes with a wooden hammer may be helpful. In cases of extreme difficulty, the bag may be opened out and a sample taken either by piffing or by coning and quartering.

5.1.3 Scale of sampling

5.1.3.1 Lot – all bags (containers) in a single consignment of the material of the same grade and type, coming out from the single batch of manufacture shall constitute a lot. If a consignment is declared to consist of different batches or sources of manufacture, the batches shall be marked separately and the groups of containers in each batch shall constitute separate lots. In case of a consignment drawn from a continuous process, 2000 bags or 100 tons of the material shall constitute a lot.

5.1.3.2 During sampling, bags (containers) must be selected at random from the lot. In order to ensure randomness of the selection, the following procedure shall be adopted: Starting from any container in the lot, count them as 1, 2, 3, . . . up to r and so on, r being the integral part of N/n . Every r th container thus counted shall be withdrawn till the requisite numbers of containers are obtained.

5.1.3.3 The number of containers to be chosen for sampling from a lot shall depend on the size of the lot and shall be as given in table 1.

Table 1 – Number of containers or packages to be selected for sampling

Lot size (N)	Number of containers/packages to be selected (n)
2 - 8	2
9 - 27	3
28 - 64	4
65 - 100	5
101 - 300	6
301 - 500	7
501 - 800	8
801 - 1300	9
1301 and above	10

5.2 Sampling of bulk fertilizers

5.2.1 Fertilizers in wagons, storage bins, truck and trailers

5.2.1.1 Apparatus

Double tube probe – This is a non-corrodible probe of 130 cm to 155 cm length as shown in Figure 2 below.

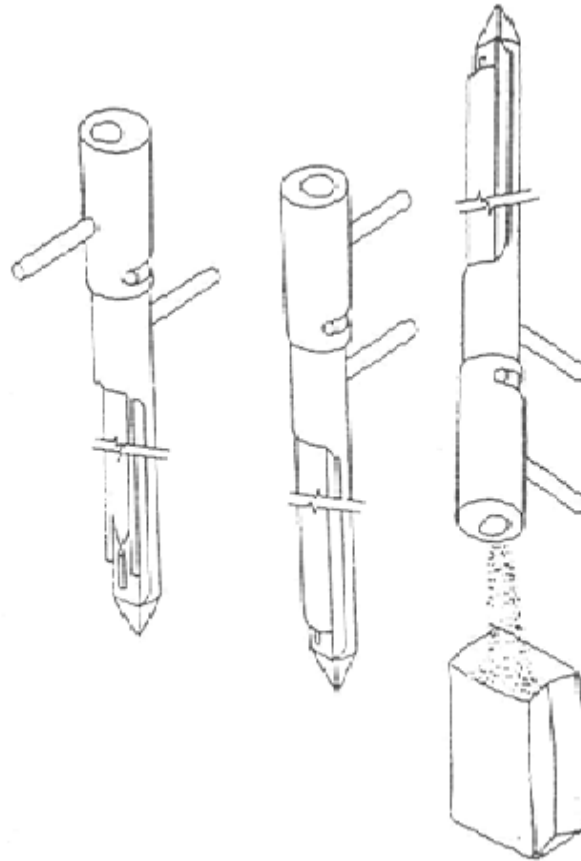

Figure 2 – Double tube probe

5.2.1.2 Procedure

The double probe tube is inserted vertically to its full depth in the open portion at the location desired. From each lot or batch take 20 samples (cores) at random portions.

5.2.2 Fertilizers from conveyor belt or chute

5.2.2.1 Apparatus

Stream sampling cup – Inside dimensions of the cup mouth are 1.9 cm x 25.4 cm. The length must be as long as maximum diameter of stream. The stream sampling cup is as shown on Figure 3 below.

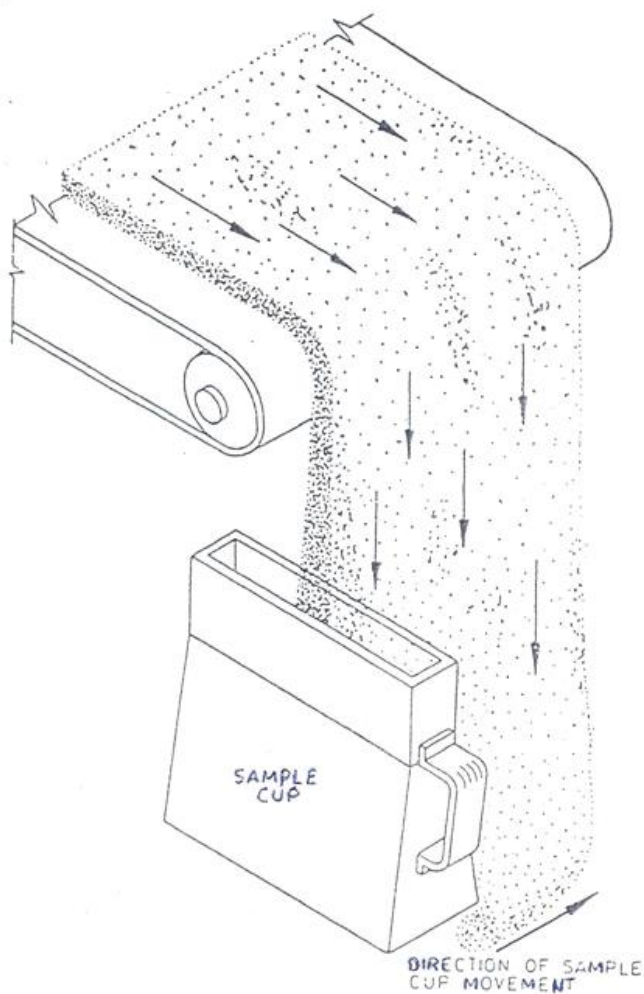

Figure 3 – Stream sampling cup

5.2.2.2 Procedure

Take 20 samples (cores) at equal intervals through the whole period of passage of a lot or batch using the stream sampling cup. In ship, sample separately from each compartment (hatch).

6 Preparation of sample

In laboratory pass the fertilizer sample through a sieve aperture 1.7 mm. Reduce the material to an amount sufficient for analysis. Sieve through a sieve aperture 1.0 mm. Grind in a mortar the part remaining on the sieve until all particles pass through. Mix thoroughly, transfer immediately to a stoppered wide-mouth bottle and preserve this as the prepared sample for analysis. Grinding and sieving shall be done as rapidly as possible to minimize gain or loss of moisture.