

มาตรฐานผลิตภัณฑ์อุตสาหกรรม ตู้เย็นและตู้เย็นแบบมีช่องแช่เยือกแข็ง สำหรับใช้ในที่อยู่อาศัย ข้อกำหนดด้านความปลอดภัย

1. บทนำ

มาตรฐานผลิตภัณฑ์อุตสาหกรรมนี้ กำหนดขึ้นโดยรับ IEC 60335-2-24:2010+A1:2012 Household and similar electrical appliances – Safety – Part 2-24 : Particular requirements for refrigerating appliances, ice-cream appliances and ice-makers มาใช้ในระดัปรับ (modified)

2. ขอบข่าย

มาตรฐานผลิตภัณฑ์อุตสาหกรรมนี้ครอบคลุมข้อกำหนดด้านความปลอดภัยของ ตู้เย็น (refrigerator) และตู้เย็นแบบมีช่องแช่เยือกแข็ง (refrigerator-freezer) สำหรับใช้ในที่อยู่อาศัยตามบทนิยามของ มอก. 455 เล่ม 1 ที่มีแรงดันไฟฟ้าที่กำหนดไม่เกิน 250 V สำหรับตู้เย็นและตู้เย็นแบบมีช่องแช่เยือกแข็งที่ใช้พลังงานไฟฟ้ากระแสสลับเฟสเดียว และแรงดันไฟฟ้าที่กำหนดไม่เกิน 480 V สำหรับตู้เย็นและตู้เย็นแบบมีช่องแช่เยือกแข็งที่ใช้พลังงานไฟฟ้ากระแสสลับมากกว่าหนึ่งเฟส และไม่เกิน 24 V สำหรับตู้เย็นและตู้เย็นแบบมีช่องแช่เยือกแข็งที่ใช้กระแสตรงจากแบตเตอรี่

มาตรฐานผลิตภัณฑ์อุตสาหกรรมนี้ครอบคลุมตู้เย็นและตู้เย็นแบบมีช่องแช่เยือกแข็งทำความเย็นด้วยระบบอัดไอสารทำความเย็น (compression-type) และใช้พลังงานไฟฟ้าจากแหล่งกำเนิดไฟฟ้าปกติ

มาตรฐานผลิตภัณฑ์อุตสาหกรรมนี้เกี่ยวข้องกับอันตรายทั่วไปที่อาจเกิดจากตู้เย็นและตู้เย็นแบบมีช่องแช่เยือกแข็งซึ่งผู้อยู่อาศัยทุกคนต้องเผชิญทั้งในและรอบๆที่อยู่อาศัยโดยทั่วไปจะไม่คำนึงถึงอันตรายที่เกิดจาก

- บุคคล (รวมถึงเด็กเล็ก)
 - ขึ้นกับสภาพร่างกาย การเข้าใจหรือความรู้ หรือ
 - การขาดประสบการณ์และความรู้
- ต้องมีการป้องกันการใช้เครื่องใช้ไฟฟ้าที่ไม่ได้รับการควบคุมดูแลอย่างปลอดภัยหรือต้องให้คำแนะนำ
- การเล่นเครื่องใช้ไฟฟ้าโดยเด็กเล็ก

หมายเหตุ 1 ข้อควรคำนึงถึงมีดังต่อไปนี้

- ตู้เย็นและตู้เย็นแบบมีช่องแช่เยือกแข็งที่มีเจตนาให้ใช้งานในยานยนต์บนเรือหรือเครื่องบินอาจต้องมีข้อกำหนดเพิ่มเติม
- ในหลายๆ ท้องถิ่น ข้อกำหนดเกี่ยวกับความปลอดภัยอาจเพิ่มเติมโดยองค์กรสาธารณสุข องค์กรพิทักษ์ผู้ใช้แรงงาน องค์กรด้านการประปา และองค์กรที่คล้ายกัน

หมายเหตุ 2 มาตรฐานผลิตภัณฑ์อุตสาหกรรมนี้ไม่ครอบคลุมถึง

- ตู้เย็นและตู้เย็นแบบมีช่องแช่เยือกแข็งที่ใช้กลางแจ้ง (open air)
- ตู้เย็นและตู้เย็นแบบมีช่องแช่เยือกแข็งที่ออกแบบสำหรับใช้ในงานอุตสาหกรรมโดยเฉพาะ
- ตู้เย็นและตู้เย็นแบบมีช่องแช่เยือกแข็งที่ใช้งานในสถานที่ที่มีสภาพแวดล้อมไม่เหมาะสม เช่น ในบรรยากาศที่ก่อให้เกิดการกัดกร่อนหรือการระเบิด (ฝุ่นละอองไอระเหยหรือก๊าซ)
- ตู้เย็นและตู้เย็นแบบมีช่องแช่เยือกแข็งที่ใช้แบตเตอรี่เกินกว่า 24 V เป็นแหล่งพลังงานผลิตความเย็นโดยตรง
- ตู้เย็นและตู้เย็นแบบมีช่องแช่เยือกแข็งที่ต้องประกอบระบบท่อสารทำความเย็นให้สมบูรณ์ทั้งระบบ ณ สถานที่ใช้งาน
- ตู้เย็นและตู้เย็นแบบมีช่องแช่เยือกแข็งที่ใช้มอเตอร์คอมเพรสเซอร์แบบแยกส่วน
- เครื่องจ่ายหรือจำหน่ายน้ำดื่มและเครื่องจ่ายหรือจำหน่ายน้ำดื่มอัตโนมัติ (IEC 60335-2-75)
- ตู้เย็นและตู้เย็นแบบมีช่องแช่เยือกแข็งหรือตู้แช่แข็งแสดงสินค้าประเภทอาหาร รวมถึงเครื่องดื่ม สำหรับการขายปลีก (IEC 60335-2-89)
- เครื่องจ่ายหรือจำหน่ายไอศกรีม

หมายเหตุ 3 มาตรฐานผลิตภัณฑ์อุตสาหกรรมนี้ยังครอบคลุมถึง

- ตู้เย็นและตู้เย็นแบบมีช่องแช่เยือกแข็งสำเร็จรูปใช้งานได้แต่ไม่มีเปลือกนอก (Enclosure)
- ตู้เย็นและตู้เย็นแบบมีช่องแช่เยือกแข็งที่มีระบบท่อสารทำความเย็นสมบูรณ์ทั้งระบบแต่ยังไม่บรรจุสารทำความเย็น
- ตู้เย็นและตู้เย็นแบบมีช่องแช่เยือกแข็งยึดกับที่ที่มีเจตนาให้ติดตั้งภายในตู้หรือฝังไว้ภายในฝาผนังหรือในตำแหน่งที่คล้ายกัน (ตู้เย็นฝังใน (built-in refrigerator))
- อื่นๆ ที่ไม่ระบุไว้ตามหมายเหตุ 2

3. บทนิยาม

ความหมายของคำที่ใช้ในมาตรฐานผลิตภัณฑ์อุตสาหกรรมนี้ ให้เป็นไปตาม IEC 60335-2-24:2010+A1:2012 ข้อ 3.

4. ข้อกำหนดทั่วไป

รายละเอียดให้เป็นไปตาม IEC 60335-2-24:2010+A1:2012 ข้อ 4.

5. ภาวะทั่วไปสำหรับการทดสอบ

รายละเอียดให้เป็นไปตาม IEC 60335-2-24:2010+A1:2012 ข้อ 5. โดยมอเตอร์คอมเพรสเซอร์ต้องเป็นไปตามมาตรฐานผลิตภัณฑ์อุตสาหกรรมมอเตอร์คอมเพรสเซอร์ เฉพาะด้านความปลอดภัย ตามมาตรฐานเลขที่ มอก. 812-2558

6. การจำแนกประเภท

รายละเอียดให้เป็นไปตาม IEC 60335-2-24:2010+A1:2012 ข้อ 6. และให้เพิ่มเติมข้อความ ดังนี้

6.1 เพิ่มเติมข้อความ

ตู้เย็นที่ทำเพื่อใช้งานในประเทศไทยต้องเป็นประเภท OI ประเภท I ประเภท II และประเภท III เท่านั้น

7. การทำเครื่องหมายและฉลาก และข้อแนะนำ

ข้อกำหนดให้เป็นไปตาม มอก.1375 ข้อ 7. ยกเว้นข้อต่อไปนี้

7.1 เพิ่มเติมข้อความ

ให้แสดงรายละเอียดต่อไปนี้ที่ตู้เย็นและตู้เย็นแบบมีช่องแช่เยือกแข็ง

- กำลังไฟฟ้าเข้าเป็นวัตต์สำหรับระบบทำความร้อนที่มากกว่า 100 W
- กำลังไฟฟ้าที่ใช้จัดฝ้าน้ำแข็งเป็นวัตต์ ถ้ามากกว่ากำลังไฟฟ้าเข้าที่กำหนด
- กระแสไฟฟ้าที่กำหนดเป็นแอมแปร์
- ระบุชั้นภูมิอากาศ SN , N , ST หรือ T โดยตู้เย็นและตู้เย็นแบบมีช่องแช่เยือกแข็งที่ใช้หรือจำหน่ายภายในประเทศไทยให้ระบุชั้นภูมิอากาศ T
- กำลังไฟฟ้าสูงสุดของหลอดไฟฟ้า เป็นวัตต์ (ไม่รวมถึงชุดหลอดไฟที่ต้องเปลี่ยนโดยผู้ทำเท่านั้น)
- มวลของสารทำความเย็นทั้งหมด
- สารทำความเย็นแบบเดี่ยว (single component refrigerant) ต้องระบุ หมายเลขสารทำความเย็นเป็นอย่างน้อย และอาจระบุหรือไม่ระบุชื่อทางเคมีและสูตรทางเคมี
- สารทำความเย็นแบบผสม (blended refrigerant) ต้องระบุอย่างน้อย 1 หัวข้อจากรายการดังนี้
 - ชื่อทางเคมีและสัดส่วนการผสมแต่ละชนิด
 - สูตรทางเคมีและสัดส่วนการผสมแต่ละชนิด
 - หมายเลขสารทำความเย็นและสัดส่วนการผสมแต่ละชนิด
 - หมายเลขสารทำความเย็นแบบผสม
- ชื่อทางเคมีหรือหมายเลขสารทำความเย็นที่เป็นส่วนประกอบหลักใช้เป็นก๊าซเป่าฉนวนความเย็น

หมายเลขสารทำความเย็นให้เป็นไปตาม ISO 817

ตู้เย็นและตู้เย็นแบบมีช่องแช่เยือกแข็งทำความเย็นด้วยระบบอัดไอสารทำความเย็น ต้องแยกแสดงกำลังไฟฟ้าเข้าที่ใช้จัดฝ้าน้ำแข็งเป็นวัตต์ ในกรณีที่กระแสไฟฟ้าที่คำนวณจากกำลังไฟฟ้าที่ใช้ในการจัดฝ้าน้ำแข็งมากกว่ากระแสไฟฟ้าที่กำหนดของตู้เย็น

ตู้เย็นและตู้เย็นแบบมีช่องแช่เยือกแข็งที่ออกแบบให้ติดตั้งอุปกรณ์ทำน้ำแข็งที่รวมไว้ในช่องแช่แข็งได้ ต้องแสดงขนาดกำลังไฟฟ้าสูงสุดของอุปกรณ์ทำน้ำแข็งที่รวมไว้ในช่องแช่แข็ง ในกรณีที่กำลังไฟฟ้ามากกว่า 100 W

ตู้เย็นและตู้เย็นแบบมีช่องแช่เยือกแข็งที่ทำความเย็นด้วยระบบอัดไอสารทำความเย็นหลายชุด ต้องระบุมวลสารทำความเย็นของแต่ละชุดด้วย

ตู้เย็นและตู้เย็นแบบมีช่องแช่เยือกแข็งทำความเย็นด้วยระบบอัดไอสารทำความเย็นที่ใช้สารทำความเย็นไวไฟต้องแสดงเครื่องหมายเตือนด้วยสัญลักษณ์ “เสียงต่อไฟไหม้”

ตู้เย็นและตู้เย็นแบบมีช่องแช่เยือกแข็งที่ใช้สารทำความเย็น R-744 สำหรับระบบทำความเย็นเกินจุดวิกฤตต้องแสดงข้อความดังนี้

- คำเตือน ระบบบรรจุสารทำความเย็นภายใต้ภาวะความดันสูง ห้ามดำเนินการใดๆ การตรวจสอบให้ทำโดยผู้ที่ได้รับการแต่งตั้งจากผู้ทำหรือผู้จำหน่าย

เครื่องใช้ไฟฟ้าที่ใช้สารทำความเย็น R-744 สำหรับระบบทำความเย็นเกินจุดวิกฤตต้องทำเครื่องหมายด้วยสัญลักษณ์ตาม ISO 7000 – 1701 (2004-01)

7.6 *เพิ่มเติมข้อความ*



สัญลักษณ์ IEC 60417-5005 (2002-10) ขั้วบวก



สัญลักษณ์ IEC 60417-5006 (2002-10) ขั้วลบ



สัญลักษณ์ ISO 7010 W021 คำเตือน “เสียงต่อไฟไหม้ / วัสดุติดไฟได้”



สัญลักษณ์ ISO 7000-1701 (2004-01) ความดัน

หมายเหตุ ข้อกำหนดของสีและรูปร่างของสัญลักษณ์ “คำเตือน เสียงต่อไฟไหม้” ให้เป็นไปตาม ISO 3864-1

7.10 *เพิ่มเติมข้อความ*

หมายเหตุ 101 เครื่องหมายแสดงตำแหน่งควบคุมสามารถเลือกกำหนดค่าอุณหภูมิเป็น (°C) ได้

7.12 *เพิ่มเติมข้อความ*

ตู้เย็นและตู้เย็นแบบมีช่องแช่เยือกแข็งทำความเย็นด้วยระบบอัดไอสารทำความเย็นที่ใช้สารทำความเย็นไวไฟ ในคู่มือแนะนำการใช้งานต้องระบุให้ทราบถึงวิธีการติดตั้ง การเคลื่อนย้าย การบำรุงรักษา การซ่อมแซม และการกำจัดที่ถูกต้อง

คำแนะนำสำหรับตู้เย็นและตู้เย็นแบบมีช่องแช่เยือกแข็งทำความเย็นด้วยระบบอัดไอสารทำความเย็น ที่ใช้สารทำความเย็นไวไฟ ต้องระบุข้อความเตือนดังนี้

- คำเตือน ในบริเวณที่ติดตั้งตู้เย็นและตู้เย็นแบบมีช่องแช่เยือกแข็งและผนังโดยรอบต้องให้มีการถ่ายเทของอากาศที่ดีและปราศจากสิ่งกีดขวาง
- คำเตือน ห้ามใช้เครื่องมือหรืออุปกรณ์ใดๆ เพื่อเร่งการขจัดฝ้าน้ำแข็งนอกเหนือไปจากที่ผู้ทำได้ระบุไว้

- **คำเตือน** ห้ามทำให้ระบบทำความเย็นเสียหาย เช่น การใช้ของมีคมชุดในช่องแช่แข็ง หรือทำให้สารทำความเย็นรั่วไหลออกมา

หมายเหตุ 103 คำเตือนนี้ครอบคลุมตู้เย็นและตู้เย็นแบบมีช่องแช่เยือกแข็งที่ผู้ใช้งานสามารถเข้าถึงระบบทำความเย็นได้ขณะใช้งานตามปกติ

- **คำเตือน** ห้ามนำเครื่องใช้ไฟฟ้าอื่นใดที่ผู้ทำไม่ได้แนะนำมาใช้ในช่องเก็บรักษาอาหาร เช่น เครื่องปั่นไอศกรีม เครื่องขจัดกลิ่นไฟฟ้า

คู่มือแนะนำการใช้งานของตู้เย็นและตู้เย็นแบบมีช่องแช่เยือกแข็งที่ใช้ฉนวนเป่าโฟมไวไฟ ต้องระบุวิธีการกำจัดเมื่อเลิกใช้งานด้วย

คำแนะนำต้องระบุข้อความดังนี้

“ไม่ควรเก็บสารที่อาจระเบิดได้ เช่น กระจงสเปรย์ที่บรรจุสารระเหยไวไฟได้ในตู้เย็น”

กรณีที่ใช้สัญลักษณ์ตาม ISO 7000-1701 (2004-01) ต้องจัดทำอธิบายความหมายด้วย

คำแนะนำต้องระบุข้อความดังนี้

ตู้เย็นและตู้เย็นแบบมีช่องแช่เยือกแข็งที่มีเจตนาให้ใช้งานภายในบ้านและที่คล้ายกัน เช่น

- พื้นที่ประกอบอาหารของพนักงานภายในร้านค้าสำนักงาน หรือภาวะแวดล้อมการทำงานอื่น
- ฟาร์มและลูกค้าของโรงแรม และที่อยู่อาศัยอื่น
- สภาวะแวดล้อมที่เป็นห้องนอนและห้องอาหาร
- การจัดงานเลี้ยงและที่คล้ายกัน

หมายเหตุ 104 ถ้าผู้ทำต้องการจำกัดการใช้งานของตู้เย็นและตู้เย็นแบบมีช่องแช่เยือกแข็งให้น้อยกว่าที่ระบุไว้ข้างต้น ควรให้ข้อมูลที่ชัดเจนไว้ในคู่มือแนะนำการใช้งาน

7.12.1 เพิ่มเติมข้อความ

กรณีที่ผู้ใช้สามารถเปลี่ยนหลอดไฟฟ้าได้เอง ผู้ทำต้องระบุวิธีการเปลี่ยนหลอดไฟฟ้าไว้ในคู่มือแนะนำการใช้งาน

ตู้เย็นและตู้เย็นแบบมีช่องแช่เยือกแข็งที่ติดตั้งอุปกรณ์ทำน้ำแข็งที่รวมไว้ในช่องแช่แข็ง ต้องมีการระบุชนิดของอุปกรณ์ทำน้ำแข็งที่รวมไว้ในช่องแช่แข็งนั้นในคู่มือแนะนำการใช้งาน

คู่มือแนะนำการใช้งานต้องระบุวิธีการติดตั้งอุปกรณ์ทำน้ำแข็งที่รวมไว้ในช่องแช่แข็ง ในกรณีที่สามารถติดตั้งเพิ่มเติมได้และติดตั้งได้เองโดยผู้ใช้งาน และกรณีที่การติดตั้งต้องกระทำโดยผู้ทำหรือศูนย์บริการเท่านั้นต้องมีการระบุไว้อย่างชัดเจนด้วย

ข้อแนะนำสำหรับช่องทำน้ำแข็งที่มีเจตนาให้ต่อกับแหล่งจ่ายน้ำประปา ต้องมีคำเตือนดังนี้

- **คำเตือน** ใช้ต่อเข้ากับแหล่งจ่ายน้ำดื่มเท่านั้น

คู่มือแนะนำการใช้งานของตู้เย็นและตู้เย็นแบบมีช่องแช่เยือกแข็งที่ติดตั้งยึดกับที่ ต้องระบุข้อความเตือนดังนี้

- **คำเตือน** เพื่อหลีกเลี่ยงอันตรายที่อาจเกิดขึ้น ให้ติดตั้งตู้เย็นตามคู่มือแนะนำการใช้งาน

มอก. 2214-25XX

IEC 60335-2-24:2010+A1:2012

7.12.4 แก้ไขข้อความ

ให้เป็นไปตามหัวข้อนี้สำหรับตู้เย็นและตู้เย็นแบบมีช่องแช่เยือกแข็งที่ติดตั้งยึดกับที่

7.14 เพิ่มเติมข้อความ

ส่วนสูงของรูปสามเหลี่ยมในสัญลักษณ์คำเตือน “เสียงต่อไฟไหม้” ต้องไม่น้อยกว่า 15 mm

ความสูงของตัวอักษรที่ใช้สำหรับเครื่องหมายแสดงชนิดของฉนวนเป่าโฟมไวไฟ (flammable insulation blowing gas) ต้องไม่น้อยกว่า 40 mm

7.15 เพิ่มเติมข้อความ

เครื่องหมายแสดงค่ากำลังไฟฟ้าสูงสุดของหลอดไฟฟ้าเป็นวัตต์ ต้องมองเห็นได้อย่างชัดเจนเมื่อมีการเปลี่ยนหลอดไฟฟ้าโดยผู้ใช้

สำหรับตู้เย็นและตู้เย็นแบบมีช่องแช่เยือกแข็งทำความเย็นด้วยระบบอัดไอสารทำความเย็น เครื่องหมายแสดงชนิดของสารทำความเย็นไวไฟและฉนวนเป่าโฟมไวไฟ คำเตือนสัญลักษณ์ : เสียงต่อไฟไหม้ ต้องมองเห็นได้ชัดเจน เมื่อเข้าถึงมอเตอร์คอมเพรสเซอร์

สำหรับตู้เย็นแบบอื่นๆ ให้แสดงเครื่องหมายแสดงชนิดของฉนวนเป่าโฟมไวไฟไว้ที่ด้านนอกของผนังตู้เย็น

7.101 ตู้เย็นและตู้เย็นแบบมีช่องแช่เยือกแข็งที่ทำงานด้วยแบตเตอรี่ ขั้วต่อแหล่งจ่ายหรือช่องทางเชื่อมต่อเข้ากับแบตเตอรี่ต้องแสดงเครื่องหมายอย่างชัดเจน

ขั้วบวกต้องแสดงด้วยเครื่องหมาย IEC60417-5005 (2002-10) และขั้วลบต้องแสดงด้วยเครื่องหมาย IEC60417-5006 (2002-10)

การตรวจสอบให้ทำโดยการตรวจพินิจ

8. การป้องกันการเข้าถึงส่วนที่มีไฟฟ้า

รายละเอียดให้เป็นไปตาม IEC 60335-2-24:2010+A1:2012 ข้อ 8.

9. การเริ่มเดินเครื่องใช้ไฟฟ้าทำงานด้วยมอเตอร์

รายละเอียดให้เป็นไปตาม IEC 60335-2-24:2010+A1:2012 ข้อ 9.

10. กำลังไฟฟ้าเข้าและกระแสไฟฟ้า

รายละเอียดให้เป็นไปตาม IEC 60335-2-24:2010+A1:2012 ข้อ 10.

11. การเกิดความร้อน

รายละเอียดให้เป็นไปตาม IEC 60335-2-24:2010+A1:2012 ข้อ 11. โดยมอเตอร์คอมเพรสเซอร์ต้องเป็นไปตามมาตรฐานผลิตภัณฑ์อุตสาหกรรมมอเตอร์คอมเพรสเซอร์ เฉพาะด้านความปลอดภัย ตามมาตรฐานเลขที่ มอก. 812-2558

12. ไม่มีข้อความ

รายละเอียดให้เป็นไปตาม IEC 60335-2-24:2010+A1:2012 ข้อ 12.

13. กระแสไฟฟ้ารั่ว และความทนทานไฟฟ้าที่อุณหภูมิทำงาน

รายละเอียดให้เป็นไปตาม IEC 60335-2-24:2010+A1:2012 ข้อ 13.

14. แรงดันไฟฟ้าเกินชั่วคราว

รายละเอียดให้เป็นไปตาม IEC 60335-2-24:2010+A1:2012 ข้อ 14.

15. ความต้านทานต่อความชื้น

รายละเอียดให้เป็นไปตาม IEC 60335-2-24:2010+A1:2012 ข้อ 15.

16. กระแสไฟฟ้ารั่ว และความทนทานไฟฟ้า

รายละเอียดให้เป็นไปตาม IEC 60335-2-24:2010+A1:2012 ข้อ 16.

17. การป้องกันโหดเกินของหม้อแปลงไฟฟ้าและวงจรที่เกี่ยวข้อง

รายละเอียดให้เป็นไปตาม IEC 60335-2-24:2010+A1:2012 ข้อ 17.

18. ความทนทาน

รายละเอียดให้เป็นไปตาม IEC 60335-2-24:2010+A1:2012 ข้อ 18.

19. การทำงานผิดปกติ

รายละเอียดให้เป็นไปตาม IEC 60335-2-24:2010+A1:2012 ข้อ 19. โดยมอเตอร์คอมเพรสเซอร์ต้องเป็นไปตามมาตรฐานผลิตภัณฑ์อุตสาหกรรมมอเตอร์คอมเพรสเซอร์ เฉพาะด้านความปลอดภัย ตามมาตรฐานเลขที่ มอก. 812-2558

20. เสถียรภาพและอันตรายทางกล

รายละเอียดให้เป็นไปตาม IEC 60335-2-24:2010+A1:2012 ข้อ 20.

21. ความแข็งแรงทางกล

รายละเอียดให้เป็นไปตาม IEC 60335-2-24:2010+A1:2012 ข้อ 21.

22. การสร้าง

รายละเอียดให้เป็นไปตาม IEC 60335-2-24:2010+A1:2012 ข้อ 22. โดยมอเตอร์คอมเพรสเซอร์ต้องเป็นไปตามมาตรฐานผลิตภัณฑ์อุตสาหกรรมมอเตอร์คอมเพรสเซอร์ เฉพาะด้านความปลอดภัย ตามมาตรฐานเลขที่ มอก. 812-2558

23. สายไฟฟ้าภายใน

รายละเอียดให้เป็นไปตาม IEC 60335-2-24:2010+A1:2012 ข้อ 23.

24. ส่วนประกอบ

รายละเอียดให้เป็นไปตาม IEC 60335-2-24:2010+A1:2012 ข้อ 24. โดยมอเตอร์คอมเพรสเซอร์ต้องเป็นไปตามมาตรฐานผลิตภัณฑ์อุตสาหกรรมมอเตอร์คอมเพรสเซอร์ เฉพาะด้านความปลอดภัย ตามมาตรฐานเลขที่ มอก. 812-2558

25. การต่อกับแหล่งจ่ายไฟฟ้าและสายอ่อนภายนอก

รายละเอียดให้เป็นไปตาม IEC 60335-2-24:2010+A1:2012 ข้อ 25. โดยมอเตอร์คอมเพรสเซอร์ต้องเป็นไปตามมาตรฐานผลิตภัณฑ์อุตสาหกรรมมอเตอร์คอมเพรสเซอร์ เฉพาะด้านความปลอดภัย ตามมาตรฐานเลขที่ มอก. 812-2558

26. ขั้วต่อสำหรับตัวนำภายนอก

รายละเอียดให้เป็นไปตาม IEC 60335-2-24:2010+A1:2012 ข้อ 26. โดยมอเตอร์คอมเพรสเซอร์ต้องเป็นไปตามมาตรฐานผลิตภัณฑ์อุตสาหกรรมมอเตอร์คอมเพรสเซอร์ เฉพาะด้านความปลอดภัย ตามมาตรฐานเลขที่ มอก. 812-2558

27. การเตรียมสำหรับการต่อลงดิน

รายละเอียดให้เป็นไปตาม IEC 60335-2-24:2010+A1:2012 ข้อ 27.

28. หมุดเกลียวและจุดต่อ

รายละเอียดให้เป็นไปตาม IEC 60335-2-24:2010+A1:2012 ข้อ 28. โดยมอเตอร์คอมเพรสเซอร์ต้องเป็นไปตามมาตรฐานผลิตภัณฑ์อุตสาหกรรมมอเตอร์คอมเพรสเซอร์ เฉพาะด้านความปลอดภัย ตามมาตรฐานเลขที่ มอก. 812-2558

29. ระยะห่างในอากาศระยะห่างตามผิวฉนวนและฉนวนตัน

รายละเอียดให้เป็นไปตาม IEC 60335-2-24:2010+A1:2012 ข้อ 29. โดยมอเตอร์คอมเพรสเซอร์ต้องเป็นไปตามมาตรฐานผลิตภัณฑ์อุตสาหกรรมมอเตอร์คอมเพรสเซอร์ เฉพาะด้านความปลอดภัย ตามมาตรฐานเลขที่ มอก. 812-2558

30. ความทนความร้อนและไฟ

รายละเอียดให้เป็นไปตาม IEC 60335-2-24:2010+A1:2012 ข้อ 30. โดยมอเตอร์คอมเพรสเซอร์ต้องเป็นไปตามมาตรฐานผลิตภัณฑ์อุตสาหกรรมมอเตอร์คอมเพรสเซอร์ เฉพาะด้านความปลอดภัย ตามมาตรฐานเลขที่ มอก. 812-2558

31. ความต้านทานการเป็นสนิม

รายละเอียดให้เป็นไปตาม IEC 60335-2-24:2010+A1:2012 ข้อ 31.

32. การแผ่รังสี ความเป็นพิษ และอันตรายที่คล้ายกัน

รายละเอียดให้เป็นไปตาม IEC 60335-2-24:2010+A1:2012 ข้อ 32.

ภาคผนวก

รายละเอียดให้เป็นไปตาม IEC 60335-2-24:2010+A1:2012 Annexes, Annex C, Annex D, Annex P, Annex AA, Annex BB, Annex CC และ Annex DD

มอก. 2214-25XX

IEC 60335-2-24:2010+A1:2012

© IEC 2015

เอกสารนี้เป็นสิทธิ์ของ IEC หากมิได้กำหนดไว้เป็นอย่างอื่นห้ามนำมาตรฐานฉบับนี้หรือ
ส่วนใดส่วนหนึ่งไปทำซ้ำหรือใช้ประโยชน์ในรูปแบบ หรือโดยวิธีใดๆ ไม่ว่าจะในรูปแบบ
อิเล็กทรอนิกส์หรือทางกล รวมถึงการถ่ายสำเนา ถ่ายไมโครฟิล์ม โดยไม่ได้รับอนุญาตเป็น
ลายลักษณ์อักษรจาก IEC ตามที่อยู่ข้างล่างหรือจากสมาชิก IEC ในประเทศผู้ร้องขอ

IEC Central Office

3 rue de Varembé CH-1211 Geneva 20, Switzerland

Tel. + 41 22 919 02 11

Fax + 41 22 919 03 00

E-mail : info@iec.ch

Web : www.iec.ch

CONTENTS

FOREWORD	13
INTRODUCTION	16
1 Scope	17
2 Normative references	18
3 Terms and definitions	19
4 General requirement.....	21
5 General conditions for the tests	21
6 Classification.....	23
7 Marking and instructions.....	23
8 Protection against access to live parts	27
9 Starting of motor-operated appliances.....	27
10 Power input and current.....	27
11 Heating	28
12 Void	31
13 Leakage current and electric strength at operating temperature	31
14 Transient overvoltages	32
15 Moisture resistance	32
16 Leakage current and electric strength	33
17 Overload protection of transformers and associated circuits	34
18 Endurance.....	34
19 Abnormal operation	34
20 Stability and mechanical hazards.....	36
21 Mechanical strength	38
22 Construction.....	38
23 Internal wiring	48
24 Components.....	48
25 Supply connection and external flexible cords	49
26 Terminals for external conductors	50
27 Provision for earthing	50
28 Screws and connections	51
29 Clearances, creepage distances and solid insulation	51
30 Resistance to heat and fire	52
31 Resistance to rusting.....	52
32 Radiation, toxicity and similar hazards	52
Annexes	55
Annex C (normative) Ageing test on motors.....	55
Annex D (normative) Thermal motor protectors.....	55

Annex P (informative) Guidance for the application of this standard to appliances used in warm damp equable climates	55
Annex AA (normative) Locked-rotor test of fan motors	56
Annex BB (informative) Method for accumulation of frost	58
Annex CC (normative) Non-sparking “n” electrical apparatus	61
Annex DD (informative) Sound manufacturing practice for compression-type appliances which use flammable refrigerant.....	62
Bibliography	63
Figure 101 – Apparatus for spillage test	53
Figure 102 – Detail of scratching tool tip	54
Figure AA.1 – Supply circuit for locked-rotor test of a single-phase fan motor.....	57
Figure BB.1 – Diagram of apparatus for water evaporation for accumulation of frost.....	59
Figure BB.2 – Apparatus for water evaporation and for accumulation of frost	60
Table 101 – Maximum temperatures for motor-compressors	30
Table 102 – Refrigerant flammability parameters	46

INTERNATIONAL ELECTROTECHNICAL COMMISSION

**HOUSEHOLD AND SIMILAR ELECTRICAL APPLIANCES –
SAFETY –****Part 2-24: Particular requirements for refrigerating appliances,
ice-cream appliances and ice-makers**

FOREWORD

- 1) The International Electrotechnical Commission (IEC) is a worldwide organization for standardization comprising all national electrotechnical committees (IEC National Committees). The object of IEC is to promote international co-operation on all questions concerning standardization in the electrical and electronic fields. To this end and in addition to other activities, IEC publishes International Standards, Technical Specifications, Technical Reports, Publicly Available Specifications (PAS) and Guides (hereafter referred to as "IEC Publication(s)"). Their preparation is entrusted to technical committees; any IEC National Committee interested in the subject dealt with may participate in this preparatory work. International, governmental and non-governmental organizations liaising with the IEC also participate in this preparation. IEC collaborates closely with the International Organization for Standardization (ISO) in accordance with conditions determined by agreement between the two organizations.
- 2) The formal decisions or agreements of IEC on technical matters express, as nearly as possible, an international consensus of opinion on the relevant subjects since each technical committee has representation from all interested IEC National Committees.
- 3) IEC Publications have the form of recommendations for international use and are accepted by IEC National Committees in that sense. While all reasonable efforts are made to ensure that the technical content of IEC Publications is accurate, IEC cannot be held responsible for the way in which they are used or for any misinterpretation by any end user.
- 4) In order to promote international uniformity, IEC National Committees undertake to apply IEC Publications transparently to the maximum extent possible in their national and regional publications. Any divergence between any IEC Publication and the corresponding national or regional publication shall be clearly indicated in the latter.
- 5) IEC itself does not provide any attestation of conformity. Independent certification bodies provide conformity assessment services and, in some areas, access to IEC marks of conformity. IEC is not responsible for any services carried out by independent certification bodies.
- 6) All users should ensure that they have the latest edition of this publication.
- 7) No liability shall attach to IEC or its directors, employees, servants or agents including individual experts and members of its technical committees and IEC National Committees for any personal injury, property damage or other damage of any nature whatsoever, whether direct or indirect, or for costs (including legal fees) and expenses arising out of the publication, use of, or reliance upon, this IEC Publication or any other IEC Publications.
- 8) Attention is drawn to the Normative references cited in this publication. Use of the referenced publications is indispensable for the correct application of this publication.
- 9) Attention is drawn to the possibility that some of the elements of this IEC Publication may be the subject of patent rights. IEC shall not be held responsible for identifying any or all such patent rights.

This consolidated version of IEC 60335-2-24 consists of the seventh edition (2010) [documents 61C/459/FDIS and 61C/461/RVD] and its amendment 1 (2012) [documents 61C/506/FDIS and 61C/509/RVD]. It bears the edition number 7.1.

The technical content is therefore identical to the base edition and its amendment and has been prepared for user convenience. A vertical line in the margin shows where the base publication has been modified by amendment 1. Additions and deletions are displayed in red, with deletions being struck through.

มอก. 2214-25XX

IEC 60335-2-24:2010+A1:2012

This part of International Standard IEC 60335 has been prepared by subcommittee 61C: Household appliances for refrigeration, of IEC technical committee 61: Safety of household and similar electrical appliances.

This seventh edition cancels and replaces the sixth edition published in 2002 including its Amendment 1 (2005) and Amendment 2 (2007). It constitutes a technical revision.

The principal changes in this edition as compared with the previous edition of IEC 60335-2-24 are as follows (minor changes are not listed):

- aligns the text with IEC 60335-1, and its Amendments 1 and 2;
- clarifies the term “household and similar use” (1, 7.12);
- updates marking requirements for supply terminals of battery operated appliances (7.6, 7.101);
- introduces requirements for appliances using transcritical refrigerant systems (3.112, 3.113, 3.114, 3.115, 3.116, 7.1, 7.6, 7.12.1, 22.103, 24.1.4, 24.102);
- introduces an enhanced flexing test (23.3);
- introduces requirements for accessible glass panels (22.116);
- clarifies tests for appliances using flammable refrigerants (22.107, Annex DD)

This publication has been drafted in accordance with the ISO/IEC Directives, Part 2.

This part 2 is to be used in conjunction with the latest edition of IEC 60335-1 and its amendments. It was established on the basis of the fourth edition (2001) of that standard.

NOTE 1 When “Part 1” is mentioned in this standard, it refers to IEC 60335-1.

This part 2 supplements or modifies the corresponding clauses in IEC 60335-1, so as to convert that publication into the IEC standard: Safety requirements for electric refrigerating appliances, ice-cream appliances and ice-makers.

When a particular subclause of Part 1 is not mentioned in this part 2, that subclause applies as far as is reasonable. When this standard states “addition”, “modification” or “replacement”, the relevant text in Part 1 is to be adapted accordingly.

NOTE 2 The following numbering system is used:

- subclauses, tables and figures that are numbered starting from 101 are additional to those in Part 1;
- unless notes are in a new subclause or involve notes in Part 1, they are numbered starting from 101, including those in a replaced clause or subclause;
- additional annexes are lettered AA, BB, etc.

NOTE 3 The following print types are used:

- requirements: in roman type;
- *test specifications: in italic type;*
- notes: in smaller roman type.

Words in **bold** in the text are defined in Clause 3. When a definition concerns an adjective, the adjective and the associated noun are also in bold.

A list of all parts of the IEC 60335 series, under the general title: *Household and similar electrical appliances – Safety*, can be found on the IEC website.

The committee has decided that the contents of the base publication and its amendments will remain unchanged until the stability date indicated on the IEC web site under "<http://webstore.iec.ch>" in the data related to the specific publication. At this date, the publication will be

- reconfirmed,
- withdrawn,
- replaced by a revised edition, or
- amended.

NOTE 4 The attention of National Committees is drawn to the fact that equipment manufacturers and testing organizations may need a transitional period following publication of a new, amended or revised IEC publication in which to make products in accordance with the new requirements and to equip themselves for conducting new or revised tests.

It is the recommendation of the committee that the content of this publication be adopted for implementation nationally not earlier than 12 months or later than 36 months from the date of publication.

The following differences exist in the countries indicated below.

- 22.101 : E12 and E17 lamp holders are checked as specified for E14 and B15 lamp holders. E26 lamp holder is checked as specified for E27 and B22 lamp holders (Japan).
- 22.110 : For unsealed glass tube heaters, the temperature requirements are different (Japan).

IMPORTANT – The “colour inside” logo on the cover page of this publication indicates that it contains colours which are considered to be useful for the correct understanding of its contents. Users should therefore print this publication using a colour printer.

INTRODUCTION

It has been assumed in the drafting of this international standard that the execution of its provisions is entrusted to appropriately qualified and experienced persons.

This standard recognizes the internationally accepted level of protection against hazards such as electrical, mechanical, thermal, fire and radiation of appliances when operated as in normal use taking into account the manufacturer's instructions. It also covers abnormal situations that can be expected in practice and takes into account the way in which electromagnetic phenomena can affect the safe operation of appliances.

This standard takes into account the requirements of IEC 60364 as far as possible so that there is compatibility with the wiring rules when the appliance is connected to the supply mains. However, national wiring rules may differ.

If an appliance within the scope of this standard also incorporates functions that are covered by another part 2 of IEC 60335, the relevant part 2 is applied to each function separately, as far as is reasonable. If applicable, the influence of one function on the other is taken into account.

When a part 2 standard does not include additional requirements to cover hazards dealt with in Part 1, Part 1 applies.

NOTE 1 This means that the technical committees responsible for the part 2 standards have determined that it is not necessary to specify particular requirements for the appliance in question over and above the general requirements.

This standard is a product family standard dealing with the safety of appliances and takes precedence over horizontal and generic standards covering the same subject.

NOTE 2 Horizontal and generic standards covering a hazard are not applicable since they have been taken into consideration when developing the general and particular requirements for the IEC 60335 series of standards. For example, in the case of temperature requirements for surfaces on many appliances, generic standards, such as ISO 13732-1 for hot surfaces, are not applicable in addition to Part 1 or part 2 standards.

An appliance that complies with the text of this standard will not necessarily be considered to comply with the safety principles of the standard if, when examined and tested, it is found to have other features that impair the level of safety covered by these requirements.

An appliance employing materials or having forms of construction differing from those detailed in the requirements of this standard may be examined and tested according to the intent of the requirements and, if found to be substantially equivalent, may be considered to comply with the standard.

HOUSEHOLD AND SIMILAR ELECTRICAL APPLIANCES – SAFETY –

Part 2-24: Particular requirements for refrigerating appliances, ice-cream appliances and ice-makers

1 Scope

This clause of Part 1 is replaced by the following.

This International Standard deals with the safety of the following appliances, their **rated voltage** being not more than 250 V for single-phase appliances, 480 V for other appliances and 24 V d.c. for appliances when battery operated.

- **refrigerating appliances** for household and similar use;
- **ice-makers** incorporating a motor-compressor and **ice-makers** intended to be incorporated in frozen food storage compartments;
- **refrigerating appliances** and **ice-makers** for use in camping, touring caravans and boats for leisure purposes.

These appliances may be operated from the mains, from a separate battery or operated either from the mains or from a separate battery.

This standard also deals with the safety of **ice-cream appliances** intended for household use, their **rated voltage** being not more than 250 V for single-phase appliances and 480 V for other appliances.

It also deals with **compression-type appliances** for household and similar use, which use **flammable refrigerants**.

This standard does not cover features of the construction and operation of those **refrigerating appliances** which are dealt with in other IEC standards.

Refrigerating appliances not intended for normal household use but which nevertheless may be a source of danger to the public, such as

- **refrigerating appliances** used in staff kitchen areas in shops, offices and other working environments,
- **refrigerating appliances** used in farm houses and by clients in hotels, motels and other residential type environments,
- **refrigerating appliances** used in bed and breakfast type environments, and
- **refrigerating appliances** used in catering and similar non-retail applications

are within the scope of this standard.

As far as is practicable, this standard deals with the common hazards presented by appliances that are encountered by all persons in and around the home. However, in general, it does not take into account

- persons (including children) whose
 - physical, sensory or mental capabilities or
 - lack of experience and knowledgeprevents them from using the appliance safely without supervision or instruction;
- children playing with the appliance.

NOTE 1 Attention is drawn to the fact that

ឆ្នាំ. 2214-25XX

IEC 60335-2-24:2010+A1:2012

- for appliances intended to be used in vehicles or on board ships or aircraft, additional requirements may be necessary;
- in many countries, additional requirements are specified by national health authorities, the national authorities responsible for the protection of labour, the national water supply authorities and similar authorities.

NOTE 2 This standard does not apply to

- appliances intended to be used in the open air;
- appliances designed exclusively for industrial purposes;
- appliances intended to be used in locations where special conditions prevail, such as the presence of a corrosive or explosive atmosphere (dust, vapour or gas);
- appliances incorporating a battery intended as a power supply for the refrigerating function;
- appliances assembled on site by the installer;
- appliances with remote motor-compressors;
- motor-compressors (IEC 60335-2-34);
- commercial dispensing appliances and vending appliances (IEC 60335-2-75);
- commercial refrigerators and freezers used for the display of food products, including beverages, for retail sale (IEC 60335-2-89);
- commercial ice-cream appliances.

2 Normative references

This clause of Part 1 is applicable except as follows.

Addition:

IEC 60068-2-11, *Environmental testing – Part 2 Tests. Tests Ka: Salt mist*

IEC 60079-4A, *Electrical apparatus for explosive gas atmospheres – Part 4: Method of test for ignition temperature – First supplement*

IEC 60079-15:2010, *Explosive atmospheres – Part 15: Equipment protection by type of protection "n"*

IEC/TR 60079-20, *Electrical apparatus for explosive gas atmospheres – Part 20: Data for flammable gases and vapours, relating to the use of electrical apparatus*

IEC 60335-2-5:2002, *Household and similar electrical appliances – Safety – Part 2-5: Particular requirements for dishwashers*

IEC 60335-2-34:2002, *Household and similar electrical appliances – Safety – Part 2-34: Particular requirements for motor-compressors*

Amendment 1 (2004)

Amendment 2 (2008)¹⁾

ISO 209, *Aluminium and aluminium alloys - Chemical composition*

ISO 817, *Refrigerants – Designation system*

ISO 4126-2:2003, *Safety devices for protection against excessive pressure – Bursting disc safety devices*

ISO 5149:1993, *Mechanical refrigerating systems used for cooling and heating – Safety requirements*

ISO 7010:2011, *Graphical symbols – Safety colours and safety signs – Registered safety signs*

¹⁾ There exists a consolidated edition 4.2 (2002) that includes edition 4 and its Amendment 1 and Amendment 2.

3 Terms and definitions

This clause of Part 1 is applicable except as follows.

3.1.9 *Replacement:*

normal operation

operation of the appliance under the following conditions

3.1.9.101

normal operation of a refrigerating appliance

operation at an ambient temperature in accordance with 5.7, empty, with the doors and lids closed. User-adjustable temperature control devices which control the operation of the motor-compressor in **compression-type appliances** are short-circuited or otherwise rendered inoperative

3.1.9.102

normal operation of an ice-maker

operation at an ambient temperature in accordance with 5.7, with the supply water at a temperature of $15\text{ °C} \pm 2\text{ °C}$

3.1.9.103

normal operation of an incorporated ice-maker

operation at the normal temperature of the frozen food storage compartment, with the supply water at a temperature of $15\text{ °C} \pm 2\text{ °C}$

3.1.9.104

normal operation of an ice-cream appliance

operation of the appliance using the maximum quantity of the mixture of ingredients indicated in the instructions; the mixture used being that which gives the most unfavourable results, the mixture being at an initial temperature of $23\text{ °C} \pm 2\text{ °C}$

3.101

refrigerating appliance

enclosed thermally insulated appliance of suitable volume for household use, cooled by an incorporated device and having one or more compartments intended for the preservation of foodstuffs including cooling of beverages

3.102

compression-type appliance

appliance in which refrigeration is effected by the vaporization at low pressure in a heat exchanger (**evaporator**) of a liquid refrigerant, the vapour thus formed being restored to the original state by mechanical compression at a higher pressure and subsequent cooling in another heat exchanger (**condenser**)

3.103

ice-maker

appliance in which ice is made by freezing water by a device consuming electrical energy and having a compartment for storing the ice

3.104

incorporated ice-maker

ice-maker specially designed to be incorporated into a frozen food storage compartment and without independent means for freezing water

3.105

heating system

heating element with associated components such as timers, switches, **thermostats** and other controls

3.106

absorption-type appliance

appliance in which refrigeration is effected by the evaporation in a heat exchanger (**evaporator**) of a liquid refrigerant, in the liquid state, the resulting vapour being then absorbed by an absorbent medium from which it is subsequently expelled at a higher partial vapour pressure by heating and liquefied by cooling in another heat exchanger (**condenser**)

3.107

condenser

heat exchanger in which, after compression, vaporized refrigerant is liquefied by losing heat to an external cooling medium

3.108

evaporator

heat exchanger in which, after pressure reduction, the liquid refrigerant is vaporized by absorbing heat from the medium to be refrigerated

3.109

flammable refrigerant

refrigerant with a flammability classification of group 2 or 3 in accordance with ISO 5149

NOTE For refrigerant blends which have more than one flammability classification, the most unfavourable classification is taken for the purposes of this definition.

3.110

ice-cream appliance

compression-type appliance which is used to make ice-cream

3.111

free space

space with a volume exceeding 60 l where a child can be entrapped and which is accessible after opening any door, lid or drawer and removing any **detachable internal part**, including shelves, containers or removable drawers which are themselves only accessible after opening any door or lid

NOTE In calculating the volume, a space with any single dimension not exceeding 150 mm or any two orthogonal dimensions, each of which do not exceed 200 mm, is ignored.

3.112

transcritical refrigeration system

refrigeration system where the pressure in the high pressure side is above the pressure where the vapour and liquid states of the refrigerant can coexist in thermodynamic equilibrium

3.113

gas cooler

heat exchanger in which, after compression the refrigerant is cooled down, by transferring heat to an external cooling medium, without changing state

NOTE A **gas cooler** is normally used in **transcritical refrigeration systems**.

3.114

design pressure (DP)

gauge pressure that has been assigned to the high pressure side of a **transcritical refrigeration system**

3.115

bursting disc

disc or foil which bursts at a predetermined pressure to reduce a pressure in a refrigeration system

3.116

pressure relief device

pressure sensing device, intended to reduce pressure automatically when pressures within the refrigeration system exceed the setting pressure of the device

4 General requirement

This clause of Part 1 is applicable except as follows.

Addition:

NOTE 101 The use of **flammable refrigerants** involves additional hazards which are not associated with appliances using non-flammable refrigerants.

This standard addresses the hazards due to ignition of leaked **flammable refrigerant** by potential ignition sources associated with the appliance.

The hazard due to ignition of leaked **flammable refrigerant** by an external potential ignition source associated with the environment in which the appliance is installed is compensated by the low probability of ignition.

5 General conditions for the tests

This clause of Part 1 is applicable except as follows.

5.2 Addition:

At least one additional specially prepared sample is required for the tests of 22.107.

NOTE 101 Unless the motor-compressor conforms to IEC 60335-2-34, at least one additional specially prepared sample may be required for the test of 19.1.

NOTE 102 At least one additional sample of the fan motor and its thermal motor protector may be required for the test of 19.1.

NOTE 103 The test of 22.7 may be performed on separate samples.

NOTE 104 Due to the potentially hazardous nature of the tests of 22.107, 22.108 and 22.109, special precautions may need to be taken when performing the tests.

5.3 Addition:

Before starting the tests,

- **ice-cream appliances** are operated empty at **rated voltage** for 1 h, or for the maximum setting of an incorporated timer, whichever is shorter;
- other **compression-type appliances** shall be operated at **rated voltage** for at least 24 h, then switched off and left to stand for at least 12 h.

The test of 11.102 is carried out immediately after the tests of Clause 13.

The test of 15.105 is carried out immediately after the test of 11.102.

The tests of 15.102, 15.103 and 15.104 are carried out immediately after the test of 15.2.

5.4 Replacement:

Tests are carried out using each source of energy (electricity, gas or other fuel) in turn. Gas appliances are supplied at the appropriate rated pressure.

Tests are additionally carried out with all combinations of energy sources supplied simultaneously unless this is prevented by interlocking devices.

5.7 Addition:

*For **ice-cream appliances**, tests specified in Clauses 10, 11 and 13 are carried out at an ambient temperature of $23\text{ °C} \pm 2\text{ °C}$.*

For other appliances, tests specified in Clauses 10, 11, 13 and subclause 19.103 are carried out at an ambient temperature of

$32\text{ °C} \pm 1\text{ °C}$ on appliances of extended temperate (SN) and temperate (N) classes;

มอก. 2214-25XX

IEC 60335-2-24:2010+A1:2012

38 °C ± 1 °C on appliances of subtropical (ST) class;

43 °C ± 1 °C on appliances of tropical (T) class.

Before starting these tests, the appliance with the doors or lids open is brought to within 2 K of the ambient temperature specified.

Appliances classified for several climatic classes are tested at the ambient temperature relevant to the highest climatic class.

Other tests are carried out at an ambient temperature of 20 °C ± 5 °C.

NOTE 101 Steady conditions are considered to be established when three successive readings of the temperature, taken at approximately 60 min intervals, at the same point of any operating cycle, do not differ by more than 1 K.

5.8.1 Addition:

Appliances which can be battery operated are tested at the more unfavourable polarity when the supply terminals or terminations for the connection of the battery have no indication for polarity.

5.9 Addition:

*Appliances incorporating an **ice-maker** are tested with the **ice-maker** operating to give the most unfavourable results.*

5.10 Addition:

For the tests of 22.107, 22.108 and 22.109, the appliance is empty and installed as outlined below:

Built-in appliances are installed in accordance with the instructions for installation.

Other appliances are placed in a test enclosure, the walls enclosing the appliance as near to all its sides and the top of the appliance as possible, unless the manufacturer indicates in the instructions for installation that a free distance shall be observed from the walls or the ceiling, in which case this distance is observed during the test.

NOTE 101 Commonly available fixing hardware, such as screws and bolts, need not be delivered with a fixed appliance.

5.101 *Appliances which are constructed so that an **ice-maker** may be incorporated are tested with the intended **ice-maker**.*

5.102 ***Compression-type appliances with heating systems** and Peltier-type appliances are tested as **combined appliances**.*

5.103 ***Compression-type appliances which use flammable refrigerants** and which, according to the instructions, may be used with other electrical appliances inside a food storage compartment are tested with such recommended appliances incorporated and being operated as in normal use.*

NOTE Examples of such electrical appliances are ice-cream makers and deodorizers.

6 Classification

This clause of Part 1 is applicable except as follows.

6.101 Appliances, other than **ice-cream appliances**, shall be of one or more of the following climatic classes:

- appliances of extended temperate class (SN);
- appliances of temperate class (N);
- appliances of subtropical class (ST);
- appliances of tropical class (T).

Compliance is checked by inspection.

NOTE The climatic classes are specified in IEC 62552.

7 Marking and instructions

This clause of Part 1 is applicable except as follows.

7.1 Addition:

Appliances shall also be marked with

- the power input, in watts, of **heating systems**, if greater than 100 W;
- the defrosting input, in watts, if greater than the input corresponding to the **rated power input**;
- **rated power input** in watts or **rated current** in amperes, except that **compression-type appliances**, other than **ice-cream appliances**, shall be marked only with the **rated current** in amperes;
- the letters SN, N, ST or T indicating the climatic class of the appliance;
- the maximum rated wattage of lamps, in watts (not applicable if the lamps can only be replaced by the manufacturer, together with a part of the appliance);
- the total mass of the refrigerant;

NOTE 101 For **absorption-type appliances** using ammonia, the total mass of the refrigerant is considered to be the mass of ammonia used.

- for a single component refrigerant, at least one of the following:

มอก. 2214-25XX

IEC 60335-2-24:2010+A1:2012

- the chemical name;
- the chemical formula;
- the refrigerant number;
- for a blended refrigerant, at least one of the following:
 - the chemical name and nominal proportion of each of the components;
 - the chemical formula and nominal proportion of each of the components;
 - the refrigerant number and nominal proportion of each of the components;
 - the refrigerant number of the refrigerant blend;
- the chemical name or refrigerant number of the principal component of the insulation blowing gas.

Refrigerant numbers are given in ISO 817.

For **compression-type appliances**, the defrosting power input in watts shall be marked separately if the current corresponding to the defrosting power input is greater than the **rated current** of the appliance.

Appliances which can be mains and battery operated shall be marked with the battery voltage.

Appliances which can be battery operated shall be marked with the type of battery, distinguishing between rechargeable and non-rechargeable batteries, if necessary, unless the type is irrelevant for the operation of the appliance.

The means provided for connection of any additional electrical supply shall be marked with the voltage and nature of the supply.

Appliances having provision for an **incorporated ice-maker** shall be marked with the maximum power input for an **incorporated ice-maker**, if greater than 100 W.

Ice-makers without automatic water level control shall be marked with the maximum permissible water level.

Appliances shall be marked with details of the source of supply other than electrical, if any.

For **compression-type refrigerating systems**, the appliance shall also be marked with the mass of the refrigerant for each separate refrigerant circuit.

Compression-type appliances which use **flammable refrigerants** shall be marked with the symbol "Caution: risk of fire".

Appliances employing R-744 in a **transcritical refrigeration system** shall be marked with the substance of the following:

WARNING: System contains refrigerant under high pressure. Do not tamper with the system. It must be serviced by qualified persons only.

Appliances employing R-744 in a **transcritical refrigeration system** shall be marked with symbol ISO 7000 – 1701 (2004-01).

7.6 Addition:



Symbol IEC 60417-5005 (2002-10) Plus; positive polarity



Symbol IEC 60417-5006 (2002-10) Minus; negative polarity



Symbol ISO 7010 W021

Warning; Risk of fire / flammable materials



Symbol ISO 7000-1701 (2004-01)

Pressure

NOTE The rules for warning signs in ISO 3864-1 apply to the colour and shape of the symbol "Caution: risk of fire."

7.10 Addition:

NOTE 101 As an alternative, temperature values in degrees Celsius may be indicated on a control scale.

7.12 Addition:

The instructions for **refrigerating appliances** and **ice-makers** for camping or similar use shall include the substance of the following:

- suitable for camping use;
- the appliance may be connected to more than one source of energy;

NOTE 101 This item is not applicable to appliances which are intended to be supplied by electricity only.

- the appliance shall not be exposed to rain

NOTE 102 This item is not applicable to appliances with a degree of protection against harmful ingress of water of at least IPX4.

The instructions for **ice-makers** not intended to be connected to the water supply shall state the substance of the following warning:

WARNING: fill with potable water only.

For **compression-type appliances** which use **flammable refrigerants**, the instructions shall include information pertaining to the installation, handling, servicing and disposal of the appliance.

The instructions for **compression-type appliances** that use **flammable refrigerants** shall additionally include the substance of the warnings listed below:

- WARNING: Keep ventilation openings, in the appliance enclosure or in the built-in structure, clear of obstruction.
- WARNING: Do not use mechanical devices or other means to accelerate the defrosting process, other than those recommended by the manufacturer.
- WARNING: Do not damage the refrigerant circuit.

NOTE 103 This warning is only applicable to appliances with refrigerating circuits which are accessible to the user.

- WARNING: Do not use electrical appliances inside the food storage compartments of the appliance, unless they are of the type recommended by the manufacturer.

For appliances which use flammable insulation blowing gases, the instructions shall include information regarding disposal of the appliance.

The instructions for **ice-cream appliances** shall include the ingredients and maximum quantity of mixtures that can be used in the appliance.

The instructions shall state the substance of the following.

Do not store explosive substances such as aerosol cans with a flammable propellant in this appliance.

If symbol ISO 7000–1701 (2004-01) is used, its meaning shall be explained.

The instructions shall include the substance of the following:

This appliance is intended to be used in household and similar applications such as

- staff kitchen areas in shops, offices and other working environments;
- farm houses and by clients in hotels, motels and other residential type environments;
- bed and breakfast type environments;
- catering and similar non-retail applications.

NOTE 104 If the manufacturer wants to limit the use of the appliance to less than the above, this has to be clearly stated in the instructions.

7.12.1 Addition:

Instructions shall include the method for replacing illuminating lamps, if the lamps can be replaced by the user.

For appliances designed for incorporating **ice-makers**, the instructions shall include the types of **ice-makers** which can be incorporated.

The instructions shall include information on the installation of **incorporated ice-makers** which are available as optional accessories and intended to be installed by the user. If it is intended that **incorporated ice-makers** are to be installed only by the manufacturer or its service agent, this shall be stated.

The instructions for **ice-makers** intended to be connected to the water supply shall state the substance of the following warning:

WARNING: Connect to potable water supply only.

The instructions for **fixed appliances** shall include the substance of the following warning:

WARNING: To avoid a hazard due to instability of the appliance, it must be fixed in accordance with the instructions.

In appliances employing R-744 in a **transcritical refrigeration system** the instructions shall include the substance of the following:

WARNING: The refrigeration system is under high pressure. Do not tamper with it. Contact qualified service personal before disposal.

7.12.4 Modification:

This subclause is also applicable to **fixed appliances**.

7.14 Addition:

The height of the triangle in the symbol "Caution: risk of fire" shall be at least 15 mm.

The height of the letters used for the marking of the type of flammable insulation blowing gas shall be at least 40 mm.

7.15 Addition:

The marking of the maximum rated wattage of illuminating lamps that can be replaced by the user shall be easily discernible while the lamp is being replaced.

For **compression-type appliances** the marking of the type of **flammable refrigerant** and of the flammable insulation blowing gas, as well as the symbol "Caution: risk of fire", shall be visible when gaining access to the motor-compressors.

For other appliances the marking of the type of flammable insulation blowing gas shall be on the external enclosure.

7.101 For appliances which can be battery operated, the supply terminals or terminations for connections to the battery shall be clearly indicated by symbols.

The positive terminal shall be indicated by symbol IEC 60417-5005 (2002-10) and the negative terminal by symbol IEC 60417-5006 (2002-10).

Compliance is checked by inspection.

8 Protection against access to live parts

This clause of Part 1 is applicable except as follows.

8.1.1 Modification:

Replace the second paragraph of the test specification by the following:

*Lamps are not removed, provided that the appliance can be isolated from the supply by means of a plug or an all-pole switch. However, during the insertion or removal of lamps, protection against contact with **live parts** of the lamp cap shall be ensured.*

9 Starting of motor-operated appliances

This clause of Part 1 is not applicable.

10 Power input and current

This clause of Part 1 is applicable except as follows.

10.1 Modification:

Replace the third dashed item of the first paragraph of the test specification by the following:

- *the appliance being operated under **normal operation** except that user adjustable temperature controls are set to give the lowest temperature.*

Addition:

The power input is considered to be stabilized when steady conditions are established or when any incorporated timer operates, whichever occurs first.

*A representative period is one between the making and the breaking of the temperature control, or between the highest and lowest values of power input measured, excluding starting power input but including the power input of the **incorporated ice-maker**, if any.*

NOTE 101 The power input of a defrosting system which is separately marked on the appliance is not taken into consideration during the test.

10.2 Modification:

Replace the third dashed item of the first paragraph of the test specification by the following:

- *the appliance being operated under **normal operation** except that user adjustable temperature controls are set to give the lowest temperature.*

Addition:

The appliance is operated for a period of 1 h or the maximum setting of an incorporated timer whichever is shorter. Excluding starting current, the maximum value of the current averaged over any 5 min period is obtained. The interval between current measurements shall not exceed 30 s.

NOTE 101 Starting current is considered to be excluded if the first current measurement is made approximately 1 min after starting.

10.101 The power input of the defrosting system shall not deviate from the defrosting power input marked on the appliance by more than the deviation shown in Table 1.

*Compliance is checked by operating the appliance at **rated voltage** and measuring the power input of the defrosting system after the power input has stabilized.*

10.102 The power input of any **heating system** shall not deviate from the power input of these systems marked on the appliance by more than the deviation shown in Table 1.

*Compliance is checked by operating the appliance at **rated voltage** and measuring the power input of the **heating system** after the power input has stabilized.*

11 Heating

This clause of Part 1 is applicable except as follows.

11.1 Modification:

Compliance is checked by determining the temperature rise of the various parts under the conditions specified in 11.2 to 11.7.

If the winding temperatures of motor-compressors exceed the values given in Table 101, compliance is checked by the test of 11.101.

The winding temperatures of motor-compressors conforming to IEC 60335-2-34 (including its Annex AA) are not measured.

11.2 Replacement:

Built-in appliances are installed in accordance with the instructions for installation.

Ice-cream appliances are placed as near to the walls of the test corner as possible, unless the manufacturer indicates in the instructions for use that a free distance shall be observed from the

walls, in which case, this distance is observed during the test. If means of ventilation are supplied by the manufacturer, they are mounted as intended.

Other appliances are placed in a test enclosure. The walls enclose the appliance as near to all its sides and above as possible, unless the manufacturer indicates in the instructions for installation that a free distance shall be observed from the walls or the ceiling, in which case this distance is observed during the test.

Dull black painted plywood approximately 20 mm thick is used for the test corner, supports and installation of **built-in appliances** and for the test enclosure for other appliances.

11.7 Replacement:

The appliance is operated until steady conditions are established.

11.8 Modification:

Replace the text above Table 3 by the following:

During the test, **protective devices** other than self-resetting thermal motor-protectors for motor-compressors shall not operate. When steady conditions are established, self-resetting thermal motor-protectors for motor-compressors shall not operate.

During the test, sealing compound, if any, shall not flow out.

During the test, temperature rises are monitored continuously.

For appliances of extended temperate (SN) or temperate (N) class, the temperature rises shall not exceed the values given in Table 3.

For appliances of subtropical (ST) or tropical (T) class, the temperature rises shall not exceed the values given in Table 3 reduced by 7 K.

Addition:

For motor-compressors not conforming to IEC 60335-2-34 (including its Annex AA), the temperatures of

- housings of motor-compressors and*
- windings of motor-compressors*

shall not exceed the values given in Table 101.

For motor-compressors conforming to IEC 60335-2-34 (including its Annex AA), the temperatures of their

- housings of motor-compressors,*
- windings of motor-compressors and*
- other parts such as its protection system and control system, and all other components that have been tested together with the motor-compressor during the tests of IEC 60335-2-34 and its Annex AA*

are not measured.

*The entry in Table 3 relating to the temperature rise of the external enclosure of **motor-operated appliances** is applicable to all appliances covered by this standard. However, it is not applicable to those parts of the external enclosure of the appliance that are,*

- for **built-in appliances**, not **accessible parts** after installation in accordance with the instructions for installation;*
- for other appliances, on that part of the appliance that according to the instructions for installation is intended to be placed against a wall with a free distance not exceeding 75 mm.*

Table 101 – Maximum temperatures for motor-compressors

<i>Part of the motor-compressor</i>	<i>Temperature °C</i>
<i>Windings with</i>	
<i>– synthetic insulation</i>	140
<i>– cellulose insulation or the like</i>	130
<i>Housing</i>	150

The temperature of ballast windings and their associated wiring shall not exceed the values specified in 12.4 of IEC 60598-1 when measured under the conditions stated.

11.101 *If the temperatures of the windings of motor-compressors other than those complying with IEC 60335-2-34 including its Annex AA are higher than the temperature limits given in Table 101, the test is carried out again, the **thermostat** or similar control device being set at the lowest temperature, and the short circuit of the user-adjustable temperature control device removed.*

The winding temperatures are measured at the end of a running cycle.

The temperatures shall be not higher than the temperature limits given in Table 101.

11.102 Any defrosting system shall not give rise to excessive temperatures.

Compliance is checked by the following test.

*The appliance is supplied at the most unfavourable voltage between 0,94 and 1,06 times the **rated voltage**:*

- in the case of appliances where defrosting is manually controlled, until the **evaporator** is coated with a layer of frost;*

- *in the case of appliances where defrosting is automatically or semi-automatically controlled, until the **evaporator** is coated with a layer of frost; however, this layer shall be not thicker than that which occurs in normal use during the intervals between the successive automatic defrosting operations or, for the semi-automatic defrosting, during the intervals between the defrosting operations recommended by the manufacturer, if any.*

NOTE 1 One method of accumulation of frost for **refrigerating appliances** is given in Annex BB.

With the defrosting system operating:

- *for **absorption-type appliances** and for **compression-type appliances** in which the defrosting system can be energized with the rest of the appliance unenergized, the supply voltage is as specified in 11.4;*
- *for other **compression-type appliances**, the supply voltage is as specified in 11.6.*

NOTE 2 The defrosting system is regarded as being able to be energized separately if this can be done without the use of a **tool**.

If the defrosting time is controlled by an adjustable device, the device is set to the time recommended by the manufacturer. If a control device is used which stops the defrosting at a given temperature or pressure, the defrosting period is automatically terminated when the control operates.

For manually controlled defrosting, the test is continued until steady conditions are established, otherwise the test is continued until the defrosting period is automatically terminated by a control device.

The temperatures of combustible materials and of electrical components liable to be affected by the defrosting operation are measured with thermocouples.

The temperatures and temperature rises shall not exceed the values given in 11.8.

NOTE 3 During the recovery period after defrosting, the thermal overload protector of the motor compressor may operate.

11.103 Heating systems, other than defrosting systems, incorporated in an appliance shall not give rise to excessive temperatures.

Compliance is checked by the following test.

Heating systems other than defrosting systems are energized as follows:

- *for **absorption-type appliances** and for **compression-type appliances** in which the **heating system** can be energized with the rest of the appliance unenergized, the supply voltage is as specified in 11.4;*
- *for other **compression-type appliances** the supply voltage is as specified in 11.6.*

NOTE The defrosting system is regarded as being able to be energized separately, if this can be done without the use of a **tool**.

The test is continued until steady conditions are established.

*Temperature rises are measured by means of thermocouples fixed on the outside surface of the insulation of the **heating systems**.*

Temperature rises shall not exceed the values given in 11.8.

12 Void

13 Leakage current and electric strength at operating temperature

This clause of Part 1 is applicable except as follows.

มอก. 2214-25XX

IEC 60335-2-24:2010+A1:2012

13.1 Addition:

The test of 13.2 does not apply to battery circuits.

13.2 Modification:

*Instead of the values specified for **class 0I appliances** and the various types of **class I appliances**, the following values apply:*

- for **class 0I appliances** 0,75 mA;*
- for **class I refrigerating appliances** the values specified for the various types of stationary **class I appliances**;*
- for other **class I appliances** 1,5 mA.*

13.3 Addition:

*The test voltage specified in Table 4 for **reinforced insulation** is applied between separate circuits for battery operation and mains supply operation.*

14 Transient overvoltages

This clause of Part 1 is applicable.

15 Moisture resistance

This clause of Part 1 is applicable except as follows.

15.2 Addition:

Lamp covers are not removed.

15.101 Appliances subject to spillage of liquid from containers onto the inside walls of the cabinet or compartment or onto the top of the cabinet shall be constructed so that such spillage does not affect their electrical insulation.

Compliance is checked by the relevant tests of 15.102, 15.103 and 15.104.

15.102 *The apparatus shown in Figure 101 is filled with water containing approximately 1 % NaCl and 0,6 % of acid rinsing agent, as specified in Annex AA of IEC 60335-2-5, to the level of the lip, and the displacement block is supported just above the water by means of any suitable release mechanism and bridge support.*

*All shelves and containers which can be removed without the use of a **tool** are removed and the appliance is disconnected from the supply. Lamp covers are not removed.*

The apparatus is supported with its base horizontal and so positioned and at such a height that when the release mechanism is operated, the water is discharged over the back and side interior walls of the cabinet or compartment including any electrical components mounted thereon, in the most unfavourable manner. The test is made only once with the apparatus in any one position, but the test may be repeated as many times as necessary in different positions, provided that there is no residual water on parts wetted by a previous test.

*Immediately after the test, the appliance shall withstand the electric strength test of 16.3 and inspection shall show that there is no trace of water on insulation which could result in a reduction of **clearances** and **creepage distances** below the values specified in Clause 29.*

Furthermore, if the inspection shows that water is in contact with the defrost heating element or its insulation, then the apparatus shall withstand the test of 22.102.

15.103 Appliances, other than **built-in appliances, ice-makers** and **ice-cream appliances** are tilted at an angle of up to 2° in relation to the position of normal use in the direction which is likely to be the most unfavourable for this test. One half-litre of water containing approximately 1 % NaCl and 0,6 % of acid rinsing agent, as specified in Annex AA of IEC 60335-2-5, is poured uniformly over the top of the appliance in approximately 60 s at the most unfavourable place from a height of approximately 50 mm with the controls in the on position and the appliance disconnected from the supply.

Immediately after the test, the appliance shall withstand the electric strength test of 16.3 and inspection shall show that there is no trace of water on insulation which could result in a reduction of **clearances** and **creepage distances** below the values specified in Clause 29.

15.104 For **ice-makers** which are directly connected to the water supply, the container, or that part of the appliance which serves as the container, is filled with water as in normal use. The inlet valve is then held open and the filling is continued for 1 min after the first evidence of overflow.

Where no spillage occurs due to operation of a device that prevents such spillage, the inlet valve is held open for a further 5 min following the operation of this device.

Immediately after the test, the appliance shall withstand the electric strength test of 16.3 and inspection shall show that there is no trace of water on insulation which could result in a reduction of **clearances** and **creepage distances** below the values specified in Clause 29.

15.105 Operation of a defrosting system shall not affect the electrical insulation of defrost heating elements.

Compliance is checked by the following test.

Immediately after the test of 11.102, the appliance shall withstand the electric strength test of 16.3 and inspection shall show that there is no trace of water on insulation which could result in a reduction of **clearances** and **creepage distances** below the values specified in Clause 29.

Furthermore, if the inspection shows that water is in contact with the defrost heating element or its insulation, then the apparatus shall withstand the test of 22.102.

16 Leakage current and electric strength

This clause of Part 1 is applicable except as follows.

16.1 Addition:

The test of 16.2 does not apply to battery circuits.

16.2 Modification:

Instead of the values specified for **class 0I appliances** and the various types of **class I appliances**, the following values apply:

- for **class 0I appliances** 0,75 mA;
- for **class I refrigerating appliances** the values specified for the various types of stationary **class I appliances**;
- for other **class I appliances** 1,5 mA.

16.3 Addition:

The test voltage specified in Table 7 for reinforced insulation is applied between separate circuits for battery operation and mains supply operation.

17 Overload protection of transformers and associated circuits

This clause of Part 1 is applicable.

18 Endurance

This clause of Part 1 is not applicable.

19 Abnormal operation

This clause of Part 1 is applicable except as follows.

19.1 Addition:

*Subclauses 19.2 and 19.3 do not apply to **heating systems**.*

In addition, fan motors and their thermal motor-protectors, if any, are subjected to the test specified in Annex AA.

NOTE 101 For any given type of fan motor and thermal motor-protection combination, this test is performed only once.

Motor compressors not conforming to IEC 60335-2-34 are subjected to the tests specified in 19.101 and 19.102 of IEC 60335-2-34 and shall also conform to 19.104 of that standard.

NOTE 102 For any given type of motor-compressor, this test is performed only once.

*Fan motors of **ice-cream appliances** are not subject to the locked-rotor test of Annex AA.*

19.7 Addition:

*Fan motors of **ice-cream appliances** are tested for 5 min.*

19.8 Addition:

This test is not applicable to three-phase motor-compressors complying with IEC 60335-2-34.

19.9 Not applicable.

19.13 Addition:

The temperature of the housing of motor-compressors other than those which comply with IEC 60335-2-34 is determined at the end of the test period and shall not exceed 150 °C.

19.101 Heating systems shall be so dimensioned and located that there is no risk of fire even in the case of abnormal operation.

Compliance is checked by inspection and the following test.

Doors and lids of the appliance are closed and the refrigerating system is switched off.

*Any **heating system** intended to be switched on and off by the user is switched on.*

***Heating systems** are continuously energized at a voltage equal to 1,1 times their **working voltage**, until steady conditions are established. If there is more than one **heating system**, they are operated each in turn, unless failure of a single component will cause two or more to operate together, in which case they are tested in combination.*

NOTE It may be necessary to short-circuit one or more components which operate during **normal operation** in order to ensure that the **heating systems** are continuously energized. **Self-resetting thermal cut-outs** are short-circuited unless they comply with 24.1.2, the number of cycles of operation being 100 000.

*The refrigerating system is not switched off if this prevents the **heating system** from operating.*

During and after the test, the appliance shall comply with 19.13.

19.102 Ice-makers and ice-cream appliances shall be constructed so that they shall not cause any risk of fire, mechanical hazard or electric shock even in the case of abnormal operation.

*Compliance is checked by applying any defect which may be expected in normal use, while the **ice-maker, incorporated ice-maker or ice-cream appliance** is operated under **normal operation at rated voltage**. Only one fault condition is reproduced at a time and the tests are made consecutively.*

*During the tests, the temperatures of the windings of the **ice-maker, incorporated ice-maker, ice-cream appliance** or of the appliance incorporating the **ice-maker** shall not exceed the values given in Table 8.*

During and after the tests, the appliance shall comply with 19.13.

NOTE 1 Examples of fault conditions are:

- timer stopping in any position;
- disconnection and reconnection of one or more phases of the supply during any part of the programme;
- open-circuiting or short-circuiting of components;
- failure of a magnetic valve;
- operation with an empty container.

NOTE 2 In general, tests are limited to those cases which may be expected to give the most unfavourable results.

NOTE 3 The tests are made with the tap closed or opened, whichever gives the more unfavourable result.

NOTE 4 For the purpose of these tests, thermal controls are not short-circuited.

NOTE 5 Components complying with the relevant IEC standard are not open-circuited or short-circuited, provided the appropriate standard covers the conditions which occur in the appliance.

NOTE 6 Water level switches complying with IEC 61058-1 are not short-circuited during these tests.

NOTE 7 The test during which the automatic filling device is held open has already been made during the test of 15.104.

19.103 Appliances intended for camping and similar use shall be constructed so that the risk of fire, mechanical hazard or electric shock is obviated as far as is practicable in the event of the appliance being operated whilst inclined.

Compliance is checked by the following test.

*The appliance is placed on a support inclined by 5° in the most unfavourable position and is operated under **normal operation at rated voltage** until steady conditions are established.*

*During the test, **non-self-resetting thermal cut-outs** which are accessible only with the aid of a **tool** or which require the replacement of a part shall not operate and no ignitable gas shall accumulate in the appliance.*

During and after the test, the appliance shall comply with 19.13.

19.104 Illuminating equipment shall not cause a hazard under abnormal operating conditions.

Compliance is checked by the following test, for which the appliance is empty, the refrigerating system is switched off or rendered inoperative, with the lamp circuit remaining operable, and doors or lids are in the most unfavourable open position or closed, whichever is the more onerous.

*The complete illuminating equipment including its protective cover, fitted with a lamp as recommended by the manufacturer, is operated for 12 h at 1,06 times the **rated voltage**.*

*If an incandescent lamp does not attain the maximum rated wattage at **rated voltage**, the voltage is varied until the maximum rated wattage is reached and is then increased to 1,06 times this voltage.*

มอก. 2214-25XX

IEC 60335-2-24:2010+A1:2012

*Illuminating equipment having discharge lamps is operated under the fault conditions specified in items a), d) and e) of 12.5.1 of IEC 60598-1, the appliance being supplied at **rated voltage** until temperature stabilization of the measured parts*

During and after the test, the appliance shall comply with 19.13.

The temperatures of ballast windings and their associated wiring shall not exceed the values specified in 12.5 of IEC 60598-1 when measured under the conditions specified.

19.105 Appliances intended for battery operation and having the polarity marked on or adjacent to the terminals or terminations shall be constructed so that the risk of fire, mechanical hazard or electric shock is obviated in the event of an inverted polarity connection.

Compliance is checked by operating the appliance under the conditions specified in Clause 11 but with a fully charged 70 Ah battery connected with reversed polarity.

During and after the test the appliance shall comply with 19.13.

20 Stability and mechanical hazards

This clause of Part 1 is applicable except as follows.

20.1 Modification:

Instead of the requirement, the following applies:

Ice-cream appliances shall have adequate stability.

20.101 Refrigerating appliances and **ice-makers** shall have adequate stability. If stability of the appliance is provided by an open door, the door shall be designed to provide support.

This requirement does not apply to **built-in appliances**.

*Compliance is checked by inspection and by the tests of 20.102, 20.103 and 20.104, which are carried out after the empty appliance has been disconnected from the supply, placed on a horizontal support and levelled in accordance with the instructions for installation, with castors and rollers, if any, oriented or adjusted to the most unfavourable position. **Fixed appliances** having a height exceeding 1,3 m are installed in accordance with the instructions for installation.*

NOTE 1 **Fixed appliances** with a height not exceeding 1,3 m are tested as free-standing appliances.

During these tests the appliance shall not tip and, after the tests, compliance with Clauses 8, 16 and 29 shall not be impaired.

NOTE 2 Any displacement of the appliance from its horizontal position by more than 2° is considered tipping.

20.102 *Appliances provided with doors shall be subjected to the following test.*

Unless otherwise specified in this standard, all door shelves, other than those which are specifically designed for storing eggs, shall be loaded using cylindrical weights having a diameter of 80 mm and a mass of 0,5 kg.

NOTE 1 If egg racks can be removed, the relevant shelf is not considered to be specifically designed for storing eggs.

As many weights as possible are placed horizontally on the door shelves starting as far as possible from the hinge and touching each other along the shelf, even if extended beyond the edge of the shelf, except for a space less than 80 mm wide at the end of the shelf.

Three of these weights are placed in each position on those shelves where the free height above the shelf is 340 mm or higher, two weights in each position on those shelves where the free height above the shelf is between 170 mm and 340 mm and one weight in each position where the free height above the shelf is less than 170 mm. Shelves that can be adjusted to different positions by the user are placed in the position which will give the most unfavourable results.

NOTE 2 If the shelf is too narrow to accommodate the weights lying flat, the weights may overhang the shelf or be tipped up.

Liquid containers located on the door are filled with a quantity of water to their full mark or, in the absence of a full mark, are completely filled.

For appliances with only one door, this is opened through an angle of approximately 90° and a weight of 2,3 kg is placed 40 mm from the edge farthest from the hinge on top of the door.

For appliances with more than one door, any two doors, in the most unfavourable combination, are opened through an angle of approximately 90°. The shelves of closed doors are not loaded. A weight of 2,3 kg is placed 40 mm from the edge farthest from the hinge on top of one of the open doors, chosen so as to give the most onerous test conditions.

The test is repeated with the door or doors opened through an angle of approximately 180° or to the limit of the door stop, whichever results in the smaller angle of opening.

Where appliances are provided with reversible doors, the test with the doors open to 180° or to the limit of the door stop, is repeated with the doors hinged on the other side in accordance with the instructions, if this will give a more unfavourable result.

20.103 *Appliances provided with sliding drawers inside food storage compartments are subjected to the following test.*

Each drawer is loaded with a uniformly distributed load/unit storage volume of the drawer of 0,5 kg/l.

NOTE Unit storage volume is the geometric volume of the drawer taking into account the free height of the space above the drawer.

In appliances provided with up to three sliding drawers within food storage compartments, one of the drawers, selected to give the most unfavourable result, is pulled to the most onerous out position or to its stops, if fitted, with the appropriate door opened through an angle of approximately 90°.

In appliances provided with more than three sliding drawers within food storage compartments, two non-adjacent drawers, selected to give the most unfavourable result, are pulled to their most onerous out position or to their stops, if fitted, with any doors necessary to gain access to the drawers opened through an angle of approximately 90°.

The door shelves on opened doors are loaded in accordance with 20.102

20.104 *Appliances provided with sliding drawers accessible without opening a door are subjected to the following test.*

Each drawer is loaded with a uniformly distributed load/unit storage volume of the compartments of 0,5 kg/l.

NOTE Unit storage volume is the geometric volume of the drawer taking into account the free height of the space above the drawer.

One drawer, selected to give the most unfavourable result is pulled to its most onerous out position or to its stops, if fitted, and a weight of 23 kg is gently applied to or suspended from the centre of the drawer.

If the appliance also is provided with a door or doors, unless otherwise specified, the door shelves are loaded as specified in 20.102.

For appliances with only one door, this is opened through an angle of approximately 90° and a weight of 2,3 kg is placed 40 mm from the edge farthest from the hinge on top of the door.

For appliances with more than one door, any two doors, in the most unfavourable combination, are opened through an angle of approximately 90°. The shelves of closed doors are not loaded. A

มอก. 2214-25XX

IEC 60335-2-24:2010+A1:2012

weight of 2,3 kg is placed 40 mm from the edge farthest from the hinge on top of one of the open doors, chosen so as to give the most onerous test conditions.

21 Mechanical strength

This clause of Part 1 is applicable except as follows.

NOTE 101 Covers of lamps within the appliance are considered likely to be damaged in normal use. Lamps are not tested.

21.101 Appliances for camping or similar use shall withstand the effects of dropping and vibration.

Compliance is checked by the following test.

The appliance is placed on a horizontal wooden panel which is dropped 50 times from a height of 50 mm onto a solid base of wood.

The appliance is then fastened in its normal position of use to a vibration-generator by means of straps around the enclosure. The type of vibration is sinusoidal, the direction is vertical and the severity is as follows:

- duration* 30 min;
- amplitude* 0,35 mm;
- sweep frequency range* 10 Hz, 55 Hz, 10 Hz;
- sweep rate* approximately one octave per minute.

After the test, the appliance shall show no damage affecting safety; in particular, no connections or parts the loosening of which may impair safety shall have loosened.

21.102 Lamps shall be protected against mechanical shocks.

Compliance is checked by applying a 75 mm ± 0,5 mm diameter sphere without appreciable force in an attempt to touch the lamp with the lamp cover in place.

The sphere shall not touch the lamp.

22 Construction

This clause of Part 1 is applicable except as follows.

22.6 *Addition:*

Thermostats, with the exception of their thermosensitive parts, shall not be in contact with the **evaporator** unless they are adequately protected against condensation on cold surfaces and against the effect of water formed during the defrosting process.

NOTE 101 Attention is drawn to the fact that fluids may flow along parts such as stems and tubes of thermostats.

22.7 *Replacement:*

Compression-type appliances, including protective enclosures of a protected cooling system, using **flammable refrigerants** shall withstand

- a pressure of 3,5 times the saturated vapour pressure of the refrigerant at 70 °C for parts exposed to the high-side pressure during normal operation;*
- a pressure of 5 times the saturated vapour pressure of the refrigerant at 20 °C for parts exposed only to low-side pressure during normal operation.*

NOTE 101 Specific constructional requirements of appliances with a protected cooling system are given in 22.107.

NOTE 102 All pressures are gauge pressures.

Compliance is checked by the following test.

The appropriate part of the appliance under test is subjected to a pressure that is gradually increased hydraulically until the required test pressure is reached. This pressure is maintained for 1 min. The part under test shall show no leakage.

NOTE 103 The test is not carried out on motor-compressors complying with IEC 60335-2-34.

22.17 Modification:

The requirement is not applicable to **refrigerating appliances** and **ice-makers**.

22.33 Addition:

Heating conductors having only one layer of insulation, shall not be in direct contact with water or ice during normal use.

NOTE 101 Frozen water is regarded as a conducting liquid.

22.101 Lampholders shall be fixed so that they do not work loose in normal use.

NOTE Normal use includes replacement of lamps.

Compliance is checked by inspection and, if necessary, by subjecting the lampholders to a torque of 0,15 Nm for E14 and B15 lampholders, and 0,25 Nm for E27 and B22 lampholders. The lampholders shall then withstand a push force and then a pull force of 10 N ± 1 N, each applied for 1 min in the direction of the axis of the lampholder.

After the tests, lampholders shall not have worked loose.

Lampholders for a fluorescent lamp shall comply with the test of 4.4.4 i) in IEC 60598-1.

22.102 Insulated wire heaters and their joints located in, and in integral contact with, thermal insulation shall be protected against entry of water.

Compliance is checked by immersing three samples of the complete heating element in water containing approximately 1 % NaCl and having a temperature of 20 °C ± 5 °C for a period of 24 h.

A voltage of 1 250 V is then applied for 15 min between the live part(s) of the heating element and the water.

During the test, no breakdown shall occur.

NOTE Connections to electrical terminals are not considered as joints.

22.103 Appliances employing a **transcritical refrigeration system** shall in the high pressure side of the refrigeration system include a **pressure relief device** on the compressor or between the compressor and the **gas cooler**. There shall be no shut off devices or other components except piping between the compressor and the **pressure relief device**, which could introduce a pressure drop.

The **pressure relief device** shall be mounted so that the refrigerant released from the system cannot cause any harm to the user of the appliance. The aperture shall be located so that it is unlikely to be obstructed in normal use.

The **pressure relief device** shall have no provisions for setting by the end user.

The operating pressure of the **pressure relief device** shall be no higher than the **design pressure** of the high pressure side.

The **design pressure** of the high pressure side shall be not less than the minimum high side test pressure required in Table 101 of IEC 60335-2-34 divided by 3.

มอก. 2214-25XX

IEC 60335-2-24:2010+A1:2012

The refrigeration system, including all components, shall withstand the pressures expected in normal and abnormal use and during standstill.

Pressure testing has to be done on the complete refrigeration system, however it can be done separately for the low pressure side and for the high pressure side.

Compliance is checked by inspection and by the following test:

*The **pressure relief device** is made inoperable and the test pressure is raised gradually*

- for the high pressure side, until a pressure not less than the minimum high side test pressure required in Table 101 of IEC 60335-2-34 is reached, however not less than 3 times the **design pressure**;*
- for the low pressure side, until a pressure not less than the minimum low side test pressure required in Table 102 of IEC 60335-2-34 is reached.*

For a refrigeration system with an intermediate pressure between high pressure side and low pressure side, all parts subjected to the intermediate pressure are considered to be on the low pressure side.

The pressure is maintained for one minute and the parts under test shall show no leakage.

NOTE The test is not carried out on motor-compressors complying with IEC 60335-2-34.

22.104 Appliances with two or more temperature control devices which control the same motor-compressor shall not cause undue operation of the thermal motor-protector of the motor-compressor.

Compliance is checked by the following test.

*The appliance is operated at **rated voltage** under **normal operation** except that user adjustable temperature control devices are set to give cyclic operation.*

When steady conditions are established, and immediately after a breaking of the first control device the second control device is activated. The thermal motor-protector of the motor-compressor shall not operate.

In the case of appliances where more than two control devices may act on a motor-compressor, the test is carried out separately with each combination of control devices.

22.105 For mains-operated appliances which can also be battery operated, the battery circuit shall be insulated from **live parts** by **double insulation** or **reinforced insulation**.

Moreover, it shall not be possible to touch **live parts** when making the connections to the battery. This applies even if covers, or other parts, which have to be removed to make the connections are **non-detachable parts**.

*Compliance is checked by inspection and by the tests specified for **double insulation** or **reinforced insulation**.*

22.106 The mass of refrigerant in **compression-type appliances** which use **flammable refrigerant** in their cooling system shall not exceed 150 g in each separate refrigerant circuit.

Compliance is checked by inspection.

22.107 Compression-type appliances with a protected cooling system and which use **flammable refrigerants** shall be constructed to avoid any fire or explosion hazard, in the event of leakage of the refrigerant from the cooling system.

NOTE 1 Separate components such as **thermostats** which contain less than 0,5 g of flammable gas are not considered liable to cause a fire or explosion hazard in the event of a leakage from the component itself.

NOTE 2 Appliances with a protected cooling system are those

- without any part of the cooling system inside a food storage compartment;

- where any part of the cooling system which is located inside a food storage compartment is constructed so that the refrigerant is contained within an enclosure with at least two layers of metallic materials separating the refrigerant from the food storage compartment. Each layer shall have a thickness of at least 0,1 mm. The enclosure has no joints other than the bonded seams of the evaporator where the bonded seam has a width of at least 6 mm;
- where any part of the cooling system which is located inside a food storage compartment has the refrigerant contained in an enclosure which itself is contained within a separate protective enclosure. If leakage from the containing enclosure occurs, the leaked refrigerant is contained within the protective enclosure and the appliance will not function as in normal use. The protective enclosure shall also withstand the test of 22.7. No critical point in the protective enclosure shall be located within the food storage compartment.

NOTE 3 Separate compartments with a common air circuit are considered to be a single compartment.

Compliance is checked by inspection and by the tests of 22.107.1, 22.107.2 and if necessary, 22.107.3.

NOTE 4 An appliance with a protected cooling system which, when tested, is found not to comply with the requirements specified for a protected cooling system, may be considered as having an unprotected cooling system if it is tested in accordance with 22.108 and found to comply with the requirements for an unprotected cooling system.

22.107.1 *A leakage is simulated at the most critical point of the cooling system. For refrigerant circuits that do not meet the corrosion requirements of 22.107.3 a leak is also simulated at any point of the cooling circuit that is nearest to an entry of a pipe or cable into a food storage compartment.*

NOTE 1 Critical points are only interconnecting joints between parts of the refrigerant circuit including the gasket of a semi-hermetic motor compressor. Aluminium to copper joints are also critical points unless they are protected against corrosion by a coating or sleeving that excludes oxygen. Welded telescopic joints of the motor-compressor housing, the welding of the pipes through the motor-compressor housing and the welding of the hermetic glass to metal seals (fusite) are not considered to be pipework joints. To find the most critical point of the cooling system, it may be necessary to carry out more than one test.

The method for simulating a leakage is to inject the refrigerant vapour through a capillary tube at the critical point. The capillary tube shall have a diameter of 0,7 mm \pm 0,05 mm and a length between 2 m and 3 m.

NOTE 2 Care should be taken that the installation of the capillary tube does not unduly influence the results of the test and that the foam does not enter the capillary tube during foaming. The capillary tube may need to be positioned before the appliance is foamed.

*During this test the appliance is tested with doors and lids closed, and is switched off or operated under **normal operation** at **rated voltage**, whichever gives the more unfavourable result.*

During a test in which the appliance is operated, gas injection is started at the same time as the appliance is first switched on.

The quantity of refrigerant of the type indicated by the manufacturer to be injected is equal to 80 % of the nominal charge of the refrigerant \pm 1,5 g or the maximum which can be injected in one hour, whichever is the smaller.

The quantity injected is taken from the vapour side of a gas bottle which shall contain enough liquid refrigerant to ensure that at the end of the test there is still liquid refrigerant left in the bottle.

If a blend can fractionate, the test is carried out using the fraction that has the smallest value of the lower explosive limit.

The gas bottle is kept at a temperature of

- a) 32 °C \pm 1 °C for leakage simulation on low-side pressure circuits;
- b) 70 °C \pm 1 °C for leakage simulation on high-side pressure circuits.

NOTE 3 The quantity of gas injected should preferably be measured by weighing the bottle.

*The concentration of leaked refrigerant is measured at least every 30 s from the beginning of the test and for at least 24 h after injection of the gas has stopped, inside and outside the food storage compartment, as close as possible to electrical components which, during **normal operation**, or **abnormal operation**, produce sparks or arcs.*

The concentration is not measured close to

- **non-self-resetting protective devices** necessary for compliance with Clause 19 even if they produce arcs or sparks during operation;
- *intentionally weak parts that become permanently open-circuited during the tests of Clause 19 even if they produce arcs or sparks during operation;*
- *electrical apparatus that has been tested and found to comply with at least the requirements in Annex CC.*

NOTE 4 The instrument used for monitoring gas concentration, such as those which use infrared sensing techniques, should have a fast response, typically 2 s to 3 s and should not unduly influence the result of the test.

NOTE 5 If gas chromatography is to be used, the gas sampling in confined areas should occur at a rate not exceeding 2 ml every 30 s.

NOTE 6 Other instruments are not precluded from being used provided that they do not unduly influence the results.

The measured value shall not exceed 75 % of the lower explosive limit of the refrigerant specified in Table 102 and shall not exceed 50 % of the lower explosive limit of the refrigerant specified in Table 102 for a period exceeding 5 min.

NOTE 7 For appliances with a protected cooling system, there are no additional requirements applicable to electrical components located inside food storage compartments.

22.107.2 *All accessible surfaces of protected cooling system components, including accessible surfaces in intimate contact with protected cooling systems, are scratched using the tool whose tip is shown in Figure 102.*

The tool is applied using the following parameters:

- *force at right angles to the surface to be tested..... 35 N ± 3 N;*
- *force parallel to the surface to be tested not exceeding 250 N.*

The tool is drawn across the surface to be tested at a rate of approximately 1 mm/s.

The surface to be tested is scratched at three different positions in a direction at right angles to the axis of the channel and at three different positions on the channel in a direction parallel to it. In the latter case, the length of the scratch shall be approximately 50 mm.

The scratches shall not cross each other.

The appropriate part of the appliance shall withstand the test of 22.7, the test pressure being reduced by 50 %.

22.107.3 *If aluminium having a purity of less than 99,5 % according to ISO 209 is used in a protected cooling system that is embedded in thermal insulation, a sample of the cooling system is subjected to the salt mist test of IEC 60068-2-11 for a test duration of 48 h.*

After the test there shall be no sign of blistering, pitting or other active corrosion of the aluminium or its coating, if any.

NOTE Aluminium with an ISO designation of Al 99,5 or an international registration record of 1050 A has a purity of 99,5 %.

22.108 For **compression-type appliances** with unprotected cooling systems and which use **flammable refrigerants**, any electrical component located inside the food storage compartment, which during **normal operation** or abnormal operation produces sparks or arcs and luminaires, shall be tested and found at least to comply with the requirements in Annex CC for group IIA gases or the refrigerant used.

This requirement does not apply to

- **non-self-resetting protective devices** necessary for compliance with Clause 19, even if they produce arcs or sparks during operation; nor to

- intentionally weak parts that become permanently open-circuited during the tests of Clause 19, even if they produce arcs or sparks during operation.

Refrigerant leakage into food storage compartments shall not result in an explosive atmosphere outside the food storage compartments in areas where electrical components that produce arcs and sparks during **normal operation** or abnormal operation or luminaires are mounted, when doors or lids remain closed or when opening or closing doors or lids, unless these components have been tested and found at least to comply with the requirements in Annex CC, for group IIA gases or the refrigerant used.

This requirement does not apply to

- **non-self-resetting protective devices** necessary for compliance with Clause 19, even if they produce arcs or sparks during operation; nor to
- intentionally weak parts that become permanently open-circuited during the tests of Clause 19 even if they produce arcs or sparks during operation.

NOTE 1 Separate components such as **thermostats** which contain less than 0,5 g of flammable gas are not considered liable to cause a fire or explosion hazard in the event of a leakage from the component itself.

NOTE 2 Appliances with an unprotected cooling system are those where at least one part of the cooling system is placed inside a food storage compartment or those which do not comply with 22.107.

NOTE 3 Other types of protection for electrical apparatus used in potentially explosive atmospheres covered by the IEC 60079 series are also acceptable.

NOTE 4 Changing of a lamp is not considered a potential explosion hazard, because the door or lid is open during this operation.

Compliance is checked by inspection, by the appropriate tests of IEC 60079-15 and by the following test.

NOTE 5 The tests called up by Annex CC may be carried out using the stoichiometric concentration of the refrigerant used. However, apparatus which has been independently tested and found to comply with Annex CC using the gas specified for group IIA need not be tested.

NOTE 6 Irrespective of the requirement given in 5.4 of IEC 60079-15, surface temperature limits are specified in 22.110.

*The test is performed in a draught-free location with the appliance switched off or operated under conditions of **normal operation at rated voltage**, whichever gives the more unfavourable result.*

During a test in which the appliance is operated, gas injection is started at the same time as the appliance is first switched on.

The test is carried out twice and is repeated a third time if one of the first tests gives more than 40 % of the lower explosive limit.

Through an appropriate orifice, 80 % of the nominal refrigerant charge $\pm 1,5$ g, in the vapour state is injected into a food storage compartment in a time not exceeding 10 min. The orifice is then closed. The injection shall be as close as possible to the centre of the back wall of the compartment at a distance from the top of the compartment approximately equal to one-third of the height of the compartment. Thirty minutes after the injection is completed, the door or lid is opened at a uniform rate in a time between 2 s and 4 s, to an angle of 90° or to the maximum possible, whichever is less.

For appliances having more than one door or lid, the most unfavourable sequence or combination for opening the lids or doors is used.

For appliances fitted with fan motors the test is done with the most unfavourable combination of motor operation.

The concentration of leaked refrigerant is measured at least every 30 s from the beginning of the test, at positions as close as possible to electrical components. However, it is not measured at the positions of

- **non-self-resetting protective devices** necessary for compliance with Clause 19, even if they produce arcs or sparks during operation;

มอก. 2214-25XX

IEC 60335-2-24:2010+A1:2012

- *intentionally weak parts that become permanently open-circuited during the tests of Clause 19, even if they produce arcs or sparks during operation.*

The concentration values are recorded for a period of 15 min after a sustained decrease is observed.

The measured value shall not exceed 75 % of the lower explosive limit of the refrigerant as specified in Table 102, and shall not exceed 50 % of the lower explosive limit of the refrigerant as specified in Table 102 for a period exceeding 5 min.

The above test is repeated, except that the door or lid is subjected to an open/close sequence at a uniform rate in a time of between 2 s and 4 s, the door or lid being opened to an angle of 90° or to the maximum possible, whichever is less, and closed during the sequence.

22.109 Compression-type appliances which use **flammable refrigerants** shall be constructed so that leaked refrigerant will not stagnate and thus cause a fire or explosion hazard in areas outside the food storage compartments where components producing arcs or sparks or luminaires are mounted.

This requirement does not apply to areas where

- **non-self-resetting protective devices** necessary for compliance with Clause 19, or
- intentionally weak parts that become permanently open-circuited during the tests of Clause 19 are mounted, even if they produce arcs or sparks during operation.

NOTE 1 Separate components such as **thermostats** which contain less than 0,5 g of flammable gas are not considered liable to cause a fire or explosion hazard in the event of a leakage of the component itself.

*Compliance is checked by the following test, unless luminaires and components that produce arcs or sparks during **normal operation** or abnormal operation, and which are mounted in the areas under consideration, have been tested and found at least to comply with the requirements in Annex CC for group IIA gases or the refrigerant used.*

NOTE 2 Irrespective of the requirement given in 5.4 of IEC 60079-15, surface temperature limits are specified in 22.110.

NOTE 3 Other types of protection for electrical apparatus used in potentially explosive atmospheres covered by the IEC 60079 series are also acceptable.

*The test is performed in a draught-free location with the appliance switched off or operated under **normal operation** at **rated voltage** whichever gives the more unfavourable result.*

During a test in which the appliance is operated, gas injection is started at the same time as the appliance is first switched on.

A quantity equal to 50 % of the refrigerant charge $\pm 1,5$ g is injected into the considered area.

Injection is to be at constant rate over a period of 1 h and is to be at the point of closest approach of

- pipework joints in external parts of the cooling circuit, or
- the gasket of semi-hermetic motor-compressors

to the electrical component under consideration; any direct injection shall be avoided.

NOTE 4 Welding telescopic joints of the motor-compressor housing, the welding of the pipes through the motor-compressor housing and the welding of the hermetic glass to metal seals (fusite) are not considered to be pipework joints.

The concentration of leaked refrigerant as close as possible to the electrical component is measured at least every 30 s from the beginning of the test until 15 min after a sustained decrease is observed.

The measured value shall not exceed 75 % of the lower explosive limit of the refrigerant as specified in Table 102, and shall not exceed 50 % of the lower explosive limit of the refrigerant as specified in Table 102 for a period exceeding 5 min.

22.110 Temperatures on surfaces that may be exposed to leakage of **flammable refrigerants** shall not exceed the ignition temperature of the refrigerant, as specified in table 102, reduced by 100 K.

Compliance is checked by measuring the appropriate surface temperatures during the tests specified in Clauses 11 and 19.

Temperatures of

- **non-self-resetting protective devices** that operate during the tests specified in Clause 19, or of
- intentionally weak parts that become permanently open-circuited during the tests specified in Clause 19

are not measured during those tests specified in Clause 19 that cause these devices to operate.

Table 102 – Refrigerant flammability parameters

Refrigerant number	Refrigerant name	Refrigerant formula	Refrigerant ignition temperature ^{a c} °C	Refrigerant lower explosive limit ^{b c d} % V/V
R50	Methane	CH ₄	537	4,4
R290	Propane	CH ₃ CH ₂ CH ₃	470	1,7
R600	n-Butane	CH ₃ CH ₂ CH ₂ CH ₃	372	1,4
R600a	Isobutane	CH(CH ₃) ₃	494	1,8

^a Values for other **flammable refrigerants** can be obtained from IEC 60079-4/IEC 60079-4A and IEC 60079-20.
^b Values for other **flammable refrigerants** can be obtained from IEC 60079-20 and ISO 5149.
^c IEC 60079-20 is the reference standard. ISO 5149 may be used if the required data is not contained in IEC 60079-20.
^d Concentration of refrigerant in dry air.

22.111 In **compression-type appliances** which use **flammable refrigerant** in their cooling system, all possible inadvertent contact points between uncoated aluminium and copper pipes or similar dissimilar metals shall be prevented from galvanic coupling by positive means such as the use of insulated sleeving or spacers.

Compliance is checked by inspection.

22.112 The doors and lids of compartments in appliances with a **free space** shall be capable of being opened from the inside.

Compliance is checked by the following test.

The empty appliance is disconnected from the supply, placed on a horizontal support and levelled in accordance with the instructions for installation, with castors and rollers, if any, oriented, adjusted or blocked so as to prevent the appliance from moving. Locks, if any, on doors or lids are left unlocked.

Doors and lids are closed for a period of 15 min.

A force is then applied to a point, equivalent to an accessible inside point, of each appropriate door or lid of the appliance, at the midpoint of the edge farthest from the hinge axis in the direction perpendicular to the plane of the lid or door.

The force shall be applied at a rate not exceeding 15 N/s and the lid or door shall open before the force exceeds 70 N.

NOTE 1 The force may be applied by means of a spring balance with the aid of a suction pad if necessary, to the point on the outer surface of the door or lid which corresponds to the accessible inside point.

NOTE 2 If the handle of the door or lid is at the mid-point of the edge farthest from the hinge axis, the force may be applied by means of a spring balance, to the handle. In this case, the value of the force required to open the door or lid from the inside may be determined by the proportional calculation relating to the distances of the handle and the accessible inside point from the hinge axis.

22.113 Drawers which are only accessible after opening a door or lid shall not contain a **free space**.

Compliance is checked by inspection and measurement.

22.114 Drawers which are accessible without opening a door or lid and which contain a **free space** shall

- have an opening in their rear wall that has a height of at least 250 mm and a width of at least two-thirds of the inner width of the drawer;

- be capable of being opened from the inside.

Compliance is checked by inspection, measurement and by the following test which is carried out with a weight of 23 kg placed inside the drawer.

The empty appliance is disconnected from the supply, placed on a horizontal support and levelled in accordance with the instructions for installation, with castors and rollers, if any, oriented, adjusted or blocked so as to prevent the appliance from moving. Locks, if any, on drawers are left unlocked.

Drawers shall be maintained closed for a period of 15 min.

A force is then applied to the drawer of the appliance at the geometrical centre of the front plane of the drawer equivalent to an accessible inside point, in the direction perpendicular to the front plane of the drawer.

The force shall be applied at a rate not exceeding 15 N/s and the drawer shall open before the force exceeds 70 N.

22.115 In appliances intended for household use and which contain compartments with a **free space**, any door or drawer giving access to these compartments shall not be fitted with a self-latching lock.

Key-operated locks shall require two independent movements to actuate the lock or be of a type that automatically ejects the key when unlocked.

NOTE Push and turn is considered to be an example of two independent movements.

Compliance is checked by inspection and test.

22.116 Accessible glass panels with an area having any two orthogonal dimensions exceeding 75 mm shall be either made from glass that shatters into small pieces when broken or be made from glass that has enhanced mechanical strength.

NOTE 1 External door finishes made of glass that are covered by a transparent adhesive covering are considered to be accessible.

*For **accessible glass panels** made from glass that shatters into small pieces when broken, compliance is checked by the following test, which is performed on two samples.*

Frames or other parts attached to the glass panel to be tested are removed and the glass is placed on a rigid horizontal flat surface.

NOTE 2 The edges of the sample to be tested are contained within a frame of adhesive tape in such a manner that the broken pieces remain in place after breakage but without hindering expansion of the sample.

The sample under test is broken by means of a test punch having a head with a mass of $75\text{ g} \pm 5\text{ g}$ and a conical tungsten carbide tip with an angle of $60^\circ \pm 2^\circ$. The punch shall be positioned approximately 13 mm in from the longest edge of the glass at the midpoint of that edge. The punch is then hit by a hammer so that the glass breaks.

A transparent mask of 50 mm x 50 mm is placed on the fractured glass except within a peripheral margin of 25 mm from the edge of the sample and a semi-circular area having a radius of 100 mm from the point of impact.

The assessment shall be undertaken on at least two areas of the sample, and the areas chosen shall contain the largest particles.

The number of crackfree particles within the mask are counted and for each assessment shall not be less than 40.

NOTE 3 In the case of curved glass, plane pieces of the same material can be used for the test.

*For **accessible glass panels** made from glass that has enhanced mechanical strength, compliance is checked by the pendulum hammer test Eha of IEC 60068-2-75.*

มอก. 2214-25XX

IEC 60335-2-24:2010+A1:2012

For the test the glass panels are supported according to their method of incorporation in the appliance.

The test is performed with three blows applied at the most critical point on two samples, the impact energy of each blow shall be 5 J.

At the conclusion of the tests the glass shall not be broken or cracked.

23 Internal wiring

This clause of Part 1 is applicable except as follows.

23.3 Modification:

Instead of the test being carried out while the appliance is in operation, it is carried out with the appliance disconnected from the supply.

The number of flexings for conductors flexed during normal use is increased to 100 000.

Addition:

NOTE 101 The requirement concerning open-coil springs does not apply to external conductors.

24 Components

This clause of Part 1 is applicable except as follows.

24.1 Addition:

Motor-compressors are not required to be separately tested in accordance with IEC 60335-2-34 nor are they required to meet the requirements of IEC 60335-2-34 if they meet the requirements of this standard.

24.1.3 Addition:

The number of operations for other switches shall be as follows:

– quick freeze switches	300
– manual and semi-automatic defrost switches	300
– door switches	50 000
– on/off switches	300

24.1.4 Addition:

– self-resetting thermal cut-outs which may influence the test results of 19.101 and which are not short-circuited during the test of 19.101	100 000
– thermostats which control the motor-compressor	100 000
– motor-compressor starting relays	100 000
– automatic thermal motor-protectors for motor-compressors of the hermetic and semi-hermetic type	minimum 2 000, but not less than the number of operations during the 15-day locked rotor test, whichever is the greater
– manual reset thermal motor-protectors for motor-compressors of the hermetic and semi-hermetic type	50
– other automatic thermal motor-protectors except for fan motors	2 000

- other manual reset thermal motor protectors
- for **pressure relief devices** of the **bursting disc** type, three separate samples of the appropriate parts of the refrigeration system are tested and the **bursting disc** shall operate in the same way for each sample tested
- electrical **pressure relief devices**
 - for automatic operation:
 - for manual reset

30

1

30 000

300

Electrical pressure relief devices shall comply with IEC 60730-2-6 and

- shall be of type 2B and type 2N;
- shall have a trip free mechanism of type 2E;
- the deviation and drift shall not exceed + 0%.

For **mechanical pressure relief devices** not falling under the scope of IEC 60730 the operating pressure must be no more than the setting of the device plus 10 %.

Pressure relief devices of the **bursting disc** type that are not certified to ISO 4126-2 shall be tested as part of the appliance to 14.3.4 of ISO 4126-2. They shall be marked with

- name, trademark or identification mark of the manufacturer or responsible vendor;
- model name or type reference.

24.3 Addition:

Voltage selection switches used in appliances for camping or similar use shall have a contact separation in all poles that provide full disconnection from the supply under overvoltage category III conditions.

24.5 Addition:

For starting capacitors, the voltage across the capacitors shall not exceed 1,3 times the rated voltage of the capacitor when the appliance is operating at 1,1 times the **rated voltage**.

24.101 Lampholders shall be of the insulated type.

Compliance is checked by inspection.

24.102 The discharge capacity of the **pressure relief device** shall be such that it is able to release an adequate amount of refrigerant so that the pressure during the release of the refrigerant does not increase beyond the pressure setting of the **pressure relief device** even if the compressor is operating.

Compliance is checked by validation of the manufacturer's calculations or by an appropriate test.

25 Supply connection and external flexible cords

This clause of Part 1 is applicable except as follows.

Addition:

This clause of Part 1 is not applicable to those parts related to motor-compressors with facilities for connecting a **supply cord**, complying with the appropriate requirements of IEC 60335-2-34.

25.2 Modification:

Replace the requirement by the following.

มอก. 2214-25XX

IEC 60335-2-24:2010+A1:2012

Mains-operated appliances shall not be provided with more than one means of connection to the supply unless

- the appliance consists of two or more completely independent units built together in one enclosure,
- the relevant circuits are adequately insulated from each other.

Appliances which can be both mains and battery operated shall be provided with a separate means for the connection of the mains and of the battery.

25.7 Modification:

Light polyvinyl chloride sheathed cord (code designation 60227 IEC 52) and heat-resistant light polyvinyl chloride sheathed cord (code designation 60227 IEC 56) are allowed regardless of the mass of the appliance.

Addition:

This subclause does not apply to flexible leads or cords used to connect an appliance to a SELV power supply.

25.13 Addition:

This subclause does not apply to flexible leads or cords used to connect an appliance to a SELV power supply.

25.23 Addition:

For appliances which can be battery operated, if the battery is placed in a separate box, the flexible lead or flexible cord used to connect the box to the appliance is considered to be an **interconnection cord**.

25.101 Appliances which can be battery operated shall have suitable means for connection of the battery.

Appliances shall be provided with terminals or flexible leads, or a flexible cord which, for connection to the battery terminals, may be fitted with clamps or other devices suitable for use with the type of battery marked on the appliance.

Compliance is checked by inspection.

26 Terminals for external conductors

This clause of Part 1 is applicable except as follows.

Addition:

This clause of Part 1 is not applicable to those parts of motor-compressors with facilities for connecting a **supply cord** and complying with the appropriate requirements of IEC 60335-2-34.

26.11 Addition:

Terminal devices in an appliance for the connection of the flexible leads or cord with **type X attachment** connecting an external battery or battery box shall be so located or shielded that there is no risk of accidental connection between battery supply terminals.

27 Provision for earthing

This clause of Part 1 is applicable except as follows.

Addition:

Compliance is not checked on parts related to motor-compressors if the motor-compressor complies with IEC 60335-2-34.

28 Screws and connections

This clause of Part 1 is applicable except as follows.

Addition:

Compliance is not checked on parts related to motor-compressors if the motor-compressor complies with IEC 60335-2-34.

29 Clearances, creepage distances and solid insulation

This clause of Part 1 is applicable except as follows.

มอก. 2214-25XX

IEC 60335-2-24:2010+A1:2012

Addition:

Compliance is not checked on parts related to motor-compressors if the motor-compressor conforms to IEC 60335-2-34. For motor-compressors not conforming to Part 2-34, the additions and modifications specified in Part 2-34 are applicable.

29.2 Addition:

Unless insulation is enclosed or located so that it is unlikely to be exposed to pollution by condensation due to normal use of the appliance, insulation in **refrigeration appliances** and **ice-makers** is in pollution degree 3 and shall have a CTI value of not less than 250. This requirement is not applicable for **functional insulation** if the **working voltage** does not exceed 50 V.

30 Resistance to heat and fire

This clause of Part 1 is applicable except as follows.

30.1 Addition:

NOTE 101 **Accessible parts** of non-metallic material within the storage compartment are regarded as external parts.

The ball pressure test is not applied to parts related to the motor-compressor if the motor-compressor complies with IEC 60335-2-34.

NOTE 102 The temperature rises attained during the test of 19.101 are not taken into account.

Modification:

*For **accessible parts** of non-metallic material within the storage compartment, the temperature of $75\text{ °C} \pm 2\text{ °C}$ is replaced by $65\text{ °C} \pm 2\text{ °C}$.*

30.2 Addition:

These tests are not applied to parts related to the motor-compressor if the motor-compressor complies with IEC 60335-2-34 with no ignition.

30.2.2 Not applicable.

31 Resistance to rusting

This clause of Part 1 is applicable.

32 Radiation, toxicity and similar hazards

This clause of Part 1 is not applicable.

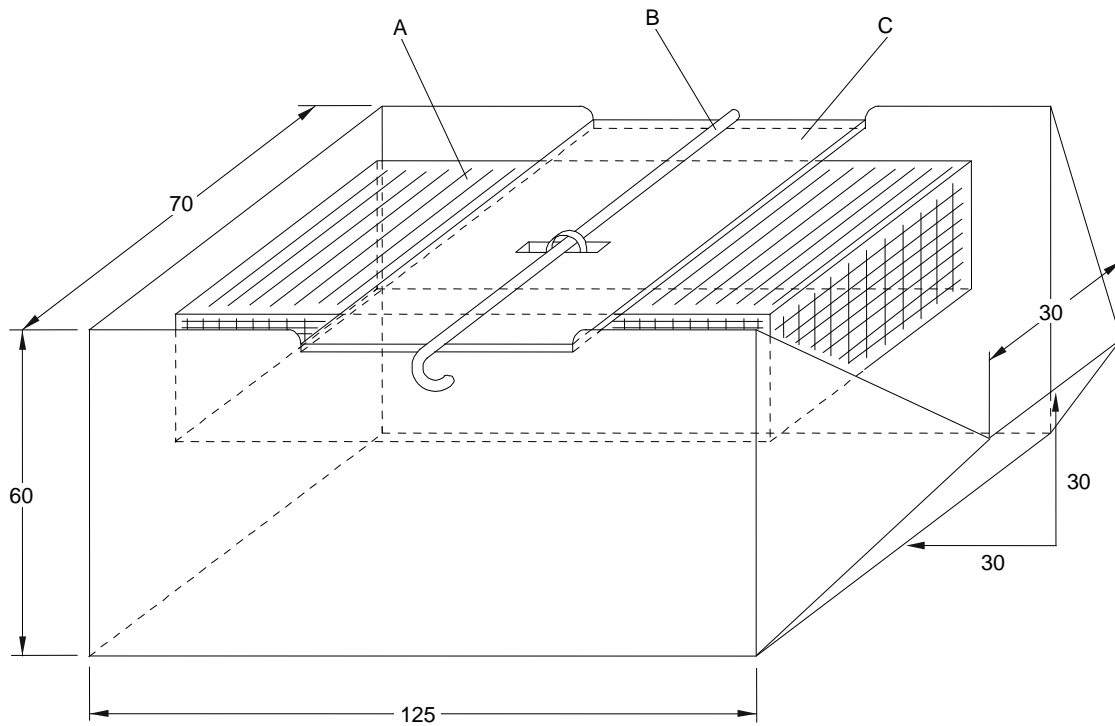

IEC 309/10

*Dimensions in millimetres***Key**

- A Displacement block
- B Release pin
- C Removable bridge support

This displacement block has a volume of $140 \text{ ml} \pm 5 \text{ ml}$ and a mass of $200 \text{ g} \pm 10 \text{ g}$. Its dimensions are approximately $112 \text{ mm} \times 50 \text{ mm} \times 25 \text{ mm}$.

The dimensions of the vessel are inside dimensions and the tolerance is ± 2 .

Figure 101 – Apparatus for spillage test

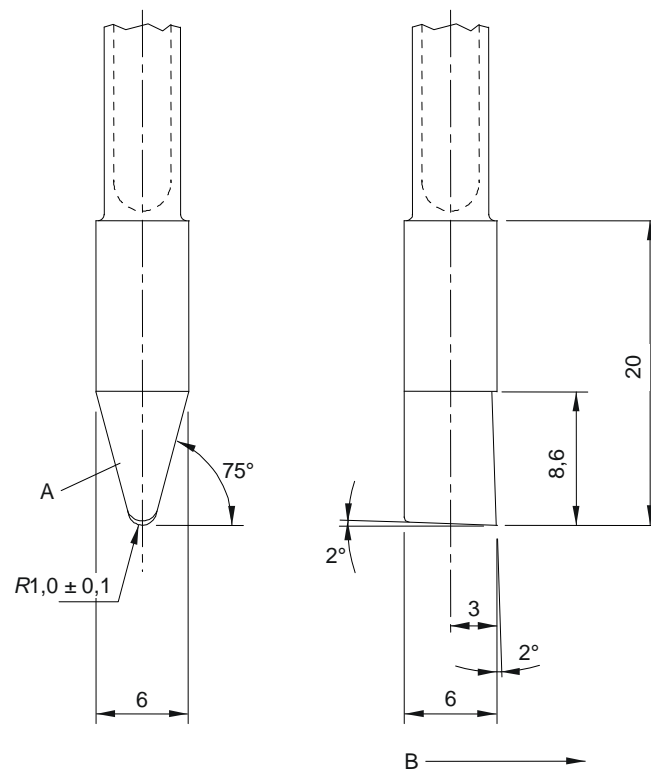

IEC 310/10

Dimensions in millimetres

Key

- A Hard-soldered carbide tip K10
- B Direction of movement

Figure 102 – Detail of scratching tool tip

Annexes

The annexes of Part 1 are applicable except as follows.

Annex C (normative)

Ageing test on motors

Addition:

This annex does not apply to motor-compressors.

Annex D (normative)

Thermal motor protectors

Addition:

This annex does not apply to motor-compressors or **condenser** fan motors.

Annex P (informative)

Guidance for the application of this standard to appliances used in warm damp equable climates

This annex of Part 1 is applicable except as follows.

5 General conditions for the tests

5.7 Modification:

The ambient temperature of the tests of Clause 10, 11 and 13 is 43 °C ± 1°C as specified for appliances of tropical (T) class in Subclause 5.7.

11 Heating

11.8 Modification:

The values of Table 3 are reduced by 18 K.

Annex AA
(normative)

Locked-rotor test of fan motors

The winding of a fan motor shall not reach excessive temperatures if the motor locks or fails to start.

Compliance is checked by the following test.

The fan and its motor are mounted on wood or similar material. The motor rotor is locked. Fan blades and motor brackets are not removed.

*The motor is supplied at **rated voltage**. The supply circuit is given in Figure AA.1.*

*The assembly is to operate under these conditions for 15 days (360 h) unless the **protective device**, if any, permanently opens the circuit prior to the expiration of that time. In this case, the test is discontinued.*

If the temperature of the motor windings stays lower than 90 °C, the test is discontinued when steady conditions are established.

Temperatures are measured under conditions specified in 11.3.

During the test, the winding temperatures shall not exceed the values given in Table 8.

72 h after the beginning of the test, the motor shall withstand the electric strength test of 16.3.

A residual current device with a rated residual current of 30 mA is connected so as to disconnect the supply in the event of an excessive earth leakage current.

*At the end of the test, the leakage current is measured between the windings and the body at a voltage equal to twice the **rated voltage**. Its value shall not exceed 2 mA.*

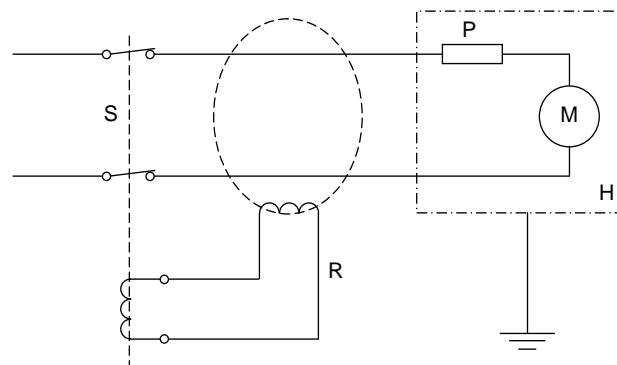

IEC 311/10

Key

S Supply source

H Housing

R Residual current device ($I_{\Delta n} = 30 \text{ mA}$)

P Thermal motor-protector (external or internal), if fitted

M Motor

NOTE 1 The circuit is modified for three-phase fan motors.

NOTE 2 Care has to be taken to complete the earthing system to permit the correct operation of the residual current device (RCCB/RCBO).

Figure AA.1 – Supply circuit for locked-rotor test of a single-phase fan motor

Annex BB (informative)

Method for accumulation of frost

*The accumulation of frost may be produced by the use of a device having a controllable heat source directed on a measured amount of water for the purpose of evaporating this water over a predetermined period with a minimum of extraneous heat loss to the cabinet of the **refrigerating appliance**.*

A convenient form of the apparatus would comprise a block enclosure of thermally insulating material having a vertical hole at its centre containing a lamp mounted on a bottom plug directly below an evaporating dish with a high thermal conductivity base and low thermal conductivity walls (see Figures BB.1 and BB.2).

*The device described above should be mounted at the geometric centre of the cabinet of the **refrigerating appliance** and the electrical connection brought conveniently to the outside so that the voltage applied may be varied and the power input measured with the door of the **refrigerating appliance** in the closed position.*

Water is then introduced into the evaporating dish at the required rate through a length of small bore tube passing into the cabinet. A continuous flow is not necessary but the water should be injected at appropriate intervals.

Provision should be made (for example in the control of the supply of electrical energy to the device) to ensure that the evaporation of water under normal conditions of use is capable of being maintained at a rate equal to 2 g of water per litre of gross cabinet volume per week.

The electrical energy to the device should not be excessive, but shall be sufficient to ensure the complete evaporation of the water.

The amount of frost to be accumulated prior to the start of the defrosting test should be based on this rate and on the time interval between two successive defrosts in accordance with the instructions.

NOTE For example, if the instructions recommend defrosting twice weekly, then a **refrigerating appliance** with a cabinet gross volume of 140 l will require:

$$2 \text{ g} \times 140 / 2 = 140 \text{ g of water}$$

The above rate may be exceeded in certain circumstances.

The apparatus described has a maximum evaporation rate of approximately 2 g/h when operating with an input of 4 W and with the water to be evaporated entering at cabinet temperature.

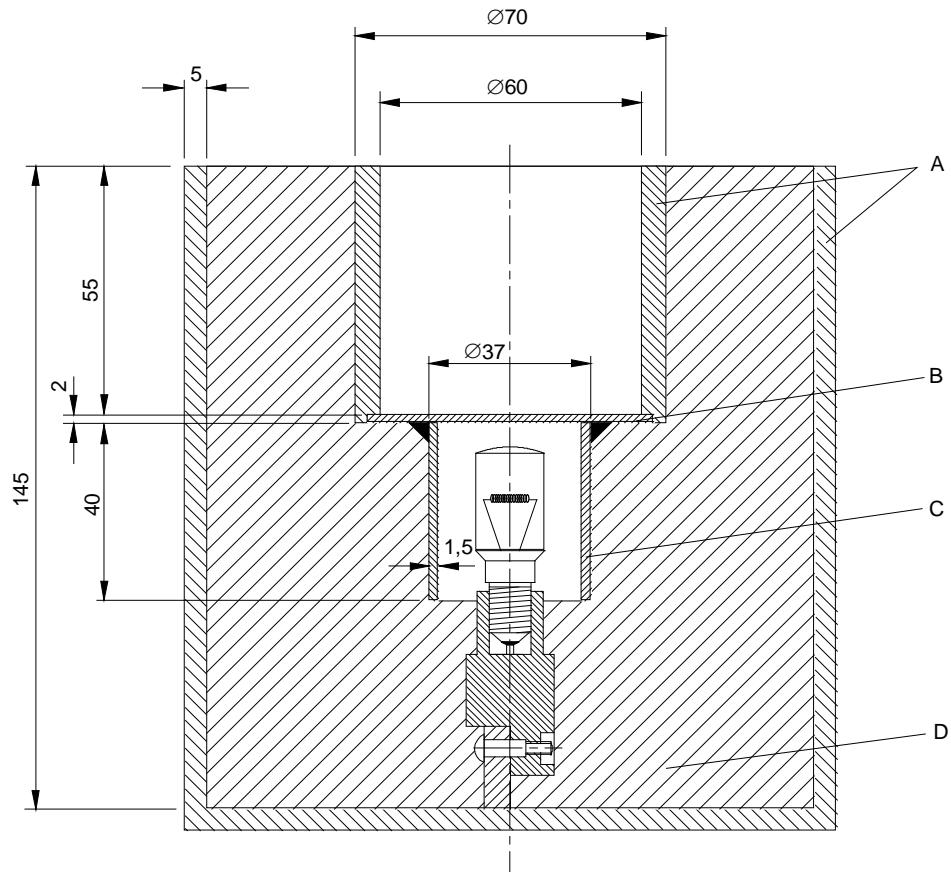

IEC 2258/02

Dimensions in millimetres

Key

- A Insulating material
- B Copper plate
- C Copper tube
- D Thermal insulating foam

Figure BB.1 – Diagram of apparatus for water evaporation for accumulation of frost

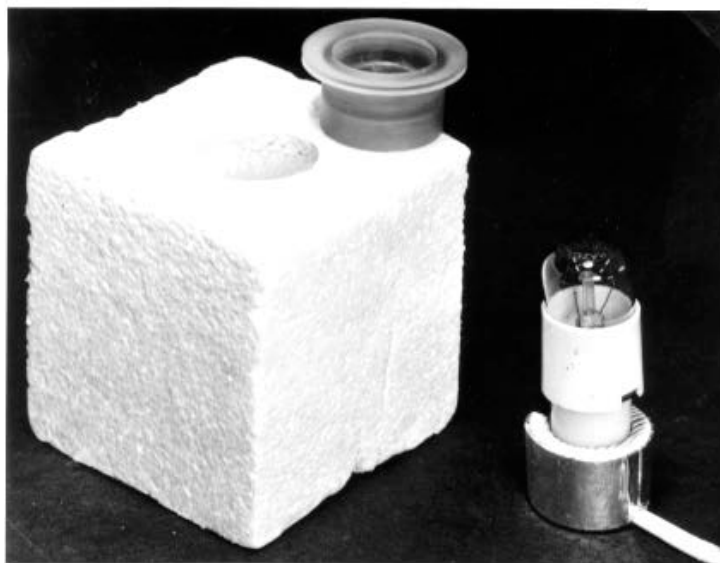
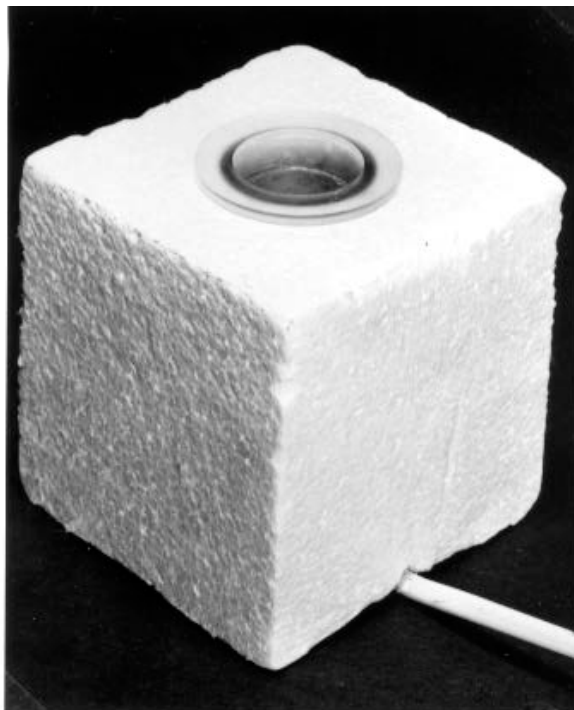

002/74

Figure BB.2 – Apparatus for water evaporation and for accumulation of frost

Annex CC
(normative)

Non-sparking “n” electrical apparatus

Where reference is made to IEC 60079-15, the following clauses are applicable as modified below.

11 Supplementary requirements for non-sparking luminaires

All of the subclauses of Clause 11 are applicable, except 11.2.4.1, 11.2.4.5, 11.2.5, 11.2.6, 11.2.7, 11.3.4, 11.3.5, 11.3.6 and 11.4.

16 General supplementary requirements for apparatus producing arcs, sparks or hot surfaces

Clause 16 is applicable.

17 Supplementary requirements for enclosed-break devices and non-incendive components producing arcs, sparks or hot surfaces

Clause 17 is applicable.

18 Supplementary requirements for hermetically sealed devices producing arcs, sparks or hot surfaces

Clause 18 is applicable.

19 Supplementary requirements for sealed devices producing arcs, sparks or hot surfaces

All of the subclauses of Clause 19 are applicable, except 19.1 and 19.6, which are replaced by the following.

19.1 Non-metallic materials

Seals are tested using 22.5. However, if the device is tested in the appliance, then 22.5.1 and 22.5.2 are not applicable. After the tests of Clause 19 in IEC 60335-2-24, by inspection, no damage that could impair the type of protection shall be evident .

19.6 Type tests

The type tests described in 22.5 shall be performed where relevant.

20 Supplementary requirements for restricted-breathing enclosures protecting apparatus producing arcs, sparks or hot surfaces

Clause 20 is applicable.

Annex DD
(informative)

**Sound manufacturing practice for compression-type
appliances which use flammable refrigerant**

For **compression-type appliances** which use **flammable refrigerant** in their cooling system the following recommendations are made concerning the manufacturing process.

All cooling circuits which are embedded in thermal insulation should be subject to a leak test prior to being embedded.

Prior to foaming there should be an inspection to ensure that there is no damage to the parts that are protected against corrosion or to the means provided for the prevention of galvanic coupling between copper and unprotected aluminium pipes.

Bibliography

The bibliography of Part 1 is applicable, except as follows.

Addition

IEC 60079 (all parts), *Explosive atmospheres*

IEC 60335-2-75, *Household and similar electrical appliances – Safety – Part 2-75: Particular requirements for commercial dispensing appliances and vending machines*

IEC 60335-2-89, *Household and similar electrical appliances – Safety – Part 2-89: Particular requirements for commercial refrigerating appliances with an incorporated or remote refrigerant condensing unit or compressor*

IEC 62552, *Household refrigerating appliances – Characteristics and test methods*

ISO 3864-1, *Graphical symbols – Safety colours and safety signs – Part 1: Design principles for safety signs in workplaces and public areas*
