

By Ministry of Industry and Technology:

AEROSOL DISPENSERS DIRECTIVE (75/324/EC)

CHAPTER 1

Objective, Scope, Legal Basis and Definitions

Objective

ARTICLE 1 – (1) The objective of this Regulation is to lay down procedures and principles concerning the essential health and safety requirements for placing on the market and the market surveillance of this aerosol dispensers.

Scope

ARTICLE 2 – (1) This Regulation shall apply to aerosol dispenser with a maximum capacity of less than 50 ml and defined in Article 5 of this Regulation except for those with a maximum capacity greater than the aerosol containers specified in Articles 3.1, 4.1.1, 4.2.1, 5.1 and 5.2, respectively in the Annex to this Regulation.

Legal Basis

ARTICLE 3 – (1) This Regulation has been prepared based on 05/03/2020 dated the Law No. 7223 on the Product Safety and Technical Regulations and dated 10/07/2018 and 1 numbered on the Presidential Decree on the Organization of the Presidency.

Compliance with the European Union Legislation

ARTICLE 4 – (1) This Regulation has been prepared based on the Directive 75/324/EEC of the European Parliament and of the Council on the Approximation of the Laws of the Member States Relating to the Aerosol Dispensers and the Directives 94/1/EC, 2008/47/EC, (EC) No. 219/2009, 2013/10/EU ve 2016/2037/EU amending this Directive.

Definitions

ARTICLE 5 – (1) For the purposes of this Regulation, the following definitions shall apply:

- a) “**EU**” means European Union,
- b) “**ADR**” means the European Agreement on The International Transportation of Dangerous Goods by Road, which entered into force with the "Decision on Determination of the Effective Dates of Some Agreements" published in the Official Gazette dated 02/07/2010 and numbered 27629 and to which Turkey is a party as of 22/03/2010.
- c) “**Aerosol Dispenser**” means any non-reusable made of metal, glass or plastic and containing a gas compressed, liquefied or dissolved under pressure, with or without a liquid, paste or powder, and fitted with a release device allowing the contents to be ejected as solid or liquid particles in suspension in a gas, as a foam, paste or powder or in a liquid state.
- ç) “**Ministry**” means the Ministry of Industry and Technology.
- d) “**Manufacturer**” means any natural or legal person who manufactures aerosol dispensers or has such dispensers designed or manufactured, and markets that aerosol dispenser under his name or trademark or uses it for his own purposes.
- e) “**Commission**” means European Commission.
- f) “**Placing on the market**” means the first making available of aerosol dispensers on the market.

(2) The other definitions in this Regulation are specified in the Article 1 of Annex of this Regulation.

CHAPTER 2

Placing on the Market, Labelling and Safety Precautions

Placing on the market

ARTICLE 6 – (1) The person responsible for the marketing of aerosol dispensers shall affix the symbol ‘3’ (inverted epsilon) to aerosol dispensers, as proof that they satisfy the requirements of this Regulation and the Annex thereto.

(2) The marketing of any aerosol dispenser which complies with the requirements of this Regulation and the Annex shall not be refused, prohibited or restricted for reasons related to the requirements laid down in this Regulation and the Annex.

Labelling

ARTICLE 7 – (1) Without prejudice to Regulation on the Classification, Labelling and Packaging of the substances and mixtures published in the Official Gazette dated 11/12/2013 and numbered 28848, each aerosol dispenser or, where particulars cannot be put on the aerosol dispenser due to its small dimensions (maximum capacity of 150 ml or less) a label attached thereto must bear the following particulars in visible, legible and indelible characters:

a) the name and address or trade mark of the person responsible for marketing the aerosol dispenser.

b) the symbol ‘3’ (inverted epsilon) certifying conformity with the requirements of this Directive.

c) code markings enabling the filling batch to be identified.

ç) the details referred to in point 2.2 of the Annex.

d) the net contents by weight and by volume.

(2) Where an aerosol dispenser contains flammable components as defined in point 1.8 of the Annex but the aerosol dispenser is not considered as ‘flammable’ or ‘extremely flammable’ according to the criteria set out in point 1.9 of the Annex, the quantity of flammable material contained in the aerosol dispenser must be stated clearly on the label, in the form of the following legible and indelible wording: ‘X % by mass of the contents are flammable.’

(3) The aerosol dispensers placed on the market shall have Turkish wording on the label.

Safety precautions

ARTICLE 8 – (1) The Ministry shall take all necessary measures to prevent the use on aerosol dispensers of markings or inscriptions which might be confused with the symbol ‘3’ (inverted epsilon).

CHAPTER 3

Transitional and Final Provisions

Penalties

ARTICLE 9 – (1) Where the Ministry notes that one or more aerosol dispensers although complying the requirements of this Regulation, represent a hazard to safety or health, it may provisionally prohibit the sale of the dispenser or dispensers or subject it or them to special conditions. It shall immediately inform the other Member States and the Commission thereof, stating the grounds for its decision.

Implementing provisions on contraventions

ARTICLE 10 – (1) Where the provisions of this Regulation are violated, the provisions of the Law No. 7223 on the Product Safety and Technical Regulations shall be applied.

Repeal

ARTICLE 11 – (1) The Regulation on the Aerosol Dispensers published in the Official Gazette, dated 30/11/2000 No. 24246 and the Regulation on the Amendment of Some Articles of the Regulation on Aerosol Dispensers published in the Official Gazette, dated 3/5/2002 No. 24744 have been repealed.

(2) References to the repealed Regulation shall be construed as references to this Regulation.

Entry into force

ARTICLE 12 – (1) This Regulation shall enter into force on the date of publication.

Execution

ARTICLE 13 – (1) This Regulation shall be executed by the Ministry of Industry and Technology.

ANNEX

1. DEFINITIONS

1.1. Pressures

‘Pressures’ means the internal pressures expressed in bars (relative pressures).

1.2. Test pressure

‘Test pressure’ means the pressure to which an unfilled aerosol dispenser container may be subjected for 25 seconds without any leakage being caused or, in the case of metal or plastic containers, any visible or permanent distortion except as allowed under 6.1.1.2.

1.3. Bursting pressure

‘Bursting pressure’ means the minimum pressure which causes the aerosol dispenser container to burst or rupture.

1.4. Total capacity of the container

‘Total capacity of the container’ means the volume in millilitres of an open container up to the rim of the opening.

1.5. Net capacity

‘Net capacity’ means the volume in millilitres of a filled and closed aerosol dispenser.

1.6. Volume of liquid phase

‘Volume of liquid phase’ means the volume of the non-gaseous phases in the filled and closed aerosol dispenser.

1.7. Test conditions

‘Test conditions’ means the values of test and bursting pressures exerted hydraulically at 20° C ($\pm 5^\circ$ C).

1.7a. Substance

‘Substance’ means substance as defined in Article 4(1) (y) of Regulation on the Classification, Labelling and Packaging of The Sunstances and Mixtures.

1.7b. Mixture

‘Mixture’ means mixture as defined in Article 4(1) (t) of Regulation on the Classification, Labelling and Packaging of The Sunstances and Mixtures.

1.8. Flammable contents

Contents of aerosols shall be considered as flammable if they contain any component which is classified as flammable:

- a) flammable liquid means a liquid having a flashpoint of not more than 93 °C.
- b) flammable solid means a solid substance or mixture which is readily combustible, or may cause or contribute to fire as a result of friction. Readily combustible solids are powdered, granular, or pasty substances or mixtures which are dangerous if they can be easily ignited by brief contact with an ignition source, such as a burning match, and if the flame spreads rapidly.
- c) flammable gas means a gas or gas mixture having a flammable range with air at 20 °C and a

standard pressure of 1,013 bar. This definition does not cover pyrophoric, self-heating or water-reactive substances and mixtures, which shall never be components of aerosol content.

1.9. Flammable aerosols

For the purpose of this Regulation, an aerosol is considered as ‘nonflammable’, ‘flammable’ or ‘extremely flammable’ according to its chemical heat of combustion and mass content of flammable components, as follows;

- a) The aerosol is classified as ‘extremely flammable’ if it contains 85 % or more flammable components and the chemical heat of combustion exceeds or is equal to 30 kJ/g,
- b) The aerosol is classified as ‘non-flammable’ if it contains 1 % or less flammable components and the chemical heat of combustion is less than 20 kJ/g,
- c) All other aerosols will be submitted to the following flammability classification procedures or shall be classified as ‘extremely flammable’. The ignition distance test, the enclosed space test and the foam flammability test shall comply with point 6.3.

1.9.1. Flammable spray aerosols

In the case of spray aerosols the classification shall be made taking into account the chemical heat of combustion and on the basis of the results of the ignition distance test, as follows:

- a) If the chemical heat of combustion is less than 20 kJ/g:
 - 1) The aerosol is classified as ‘flammable’ if ignition occurs at a distance equal or greater than 15 cm but less than 75 cm;
 - 2) The aerosol is classified as ‘extremely flammable’ if ignition occurs at a distance of 75 cm or more;
 - 3) If no ignition occurs in the ignition distance test, the enclosed space test shall be performed and in this case, the aerosol is classified as ‘flammable’ if the time equivalent is less than or equal to 300 s/m³ or the deflagration density is less than or equal to 300 g/m³; otherwise the aerosol is classified as ‘non-flammable’;
- b) If the chemical heat of combustion is equal to or more than 20 kJ/g, the aerosol is classified as ‘extremely flammable’ if ignition occurs at a distance of 75 cm or more; otherwise the aerosol is classified as ‘flammable’.

1.9.2. Flammable foam aerosols

In the case of foam aerosols, the classification shall be made on the basis of the results of the foam flammability test.

- a) The aerosol product shall be classified as ‘extremely flammable’ if:
 - 1) the flame height is 20 cm or more and the flame duration is two seconds or more; or
 - 2) the flame height is 4 cm or more and the flame duration is seven seconds or more.
- b) The aerosol product which does not meet the criteria in (a) is classified as ‘flammable’ if the flame height is 4 cm or more and the flame duration is two seconds or more.

1.10. Chemical Heat of Combustion

The chemical heat of combustion ΔH_c shall be either determined by: (a) acknowledged rules of technology, described e.g. in standards such as ASTM D 240, ISO 13943 86.1 to 86.3 and NFPA 30B, or found in the scientifically established literature; or (b) applying the following calculation method: The chemical heat of combustion (ΔH_c), in kilojoules per gram (kJ/g), can be calculated as the product of the theoretical heat of combustion (ΔH_{comb}), and a combustion efficiency, usually less than 1,0 (a typical combustion efficiency is 0,95 or 95 %). For a composite aerosol formulation, the chemical heat of combustion is the summation of the weighted heats of combustion for the individual components, as follows;

$$\Delta H_c = \sum_i^n \left[w_i\% \times \Delta H_{c(i)} \right]$$

ΔH_c = chemical heat of combustion (kJ/g) of the product,

$w_i\%$ = mass fraction of component i in the product,

$\Delta H_{c(i)}$ = specific heat of combustion (kJ/g) of component i in the product.

The person responsible for the marketing of the aerosol dispenser has to describe the method used for determining the chemical heat of combustion in a document to be made readily available in Turkish and/or the language accepted by the Ministry at the address specified on the label, if the chemical heat of combustion is used as a parameter for assessing the flammability of aerosols according to the provisions of this Regulation.

2. GENERAL PROVISIONS

Without prejudice to specific provisions of the Annex on requirements related to the flammability and pressure hazard, the person responsible for the marketing of aerosol dispensers is under an obligation to analyse the hazards in order to identify those which apply to his aerosol dispensers. Where appropriate, this analysis shall include a consideration of the risks resulting from the inhalation of the spray ejected by the aerosol dispenser under normal and reasonably foreseeable conditions of use, taking into account droplet size distribution in conjunction with physical and chemical properties of the contents. He must then design, construct and test it and, if applicable, draft special statements concerning its use, taking account of his analysis.

2.1-Construction and equipment

2.1.1-The filled aerosol dispenser must be such that, under normal conditions of use and storage, it complies with the provisions of this Annex.

2.1.2-The valve must enable the aerosol dispenser to be virtually hermetically sealed under normal conditions of storage or transport and must be protected, for example by means of a protective cap, against any unintentional opening and any deterioration

2.1.3-There must be no possibility that the mechanical resistance of the aerosol dispenser can be impaired by the action of the substances contained in it, even during prolonged storage.

2.2- Labelling

Without prejudice to Regulation on the Classification, Labelling and Packaging of The Sunstances and Mixtures, each aerosol dispenser must visibly bear the following legible and indelible marking:

a) Where the aerosol is classified as ‘non-flammable’ according to the criteria of point 1.9, the signal word ‘Warning’ and the other label elements for Aerosols Category 3 provided for in Graph 2.3.1 of Annex I to Regulation on the Classification, Labelling and Packaging of The Sunstances and Mixtures.

b) Where the aerosol is classified as 'flammable' according to the criteria of point 1.9, the signal word 'Warning' and the other label elements for Aerosols Category 2 provided for in Graph 2.3.1 of Annex I to Regulation on the Classification, Labelling and Packaging of The Sunstances and Mixtures.

c) Where the aerosol is classified as 'extremely flammable' according to the criteria of point 1.9, the signal word 'Danger' and the other label elements for Aerosols Category 1 provided for in Graph 2.3.1 of Annex I to Regulation on the Classification, Labelling and Packaging of The Sunstances and Mixtures.

ç) Where the aerosol dispenser is a consumer product, the precautionary statement P102 provided for in Part 1, Table 6.1 of Annex IV to Regulation on the Classification, Labelling and Packaging of The Sunstances and Mixtures.

d) Any additional operating precautions which alert consumers to the specific dangers of the product; if the aerosol dispenser is accompanied by separate instructions for use, the latter must also reflect such operating precautions.

2.3- Volume of the liquid phase

The volume of the liquid phase at 50 °C must not exceed 90 % of the net capacity.

3. SPECIAL PROVISIONS FOR METAL AEROSOL DISPENSERS

3.1- Capacity

The total capacity of these containers may not exceed 1 000 ml.

3.1.1-Test pressure of the container

a) For containers filled at a pressure of less than 6,7 bars at 50° C, the test pressure must be equal to at least 10 bars.

b) For containers filled at a pressure equal to or greater than 6,7 bars at 50° C, the test pressure must be 50 % higher than the internal pressure at 50° C.

3.1.2-Filling

The pressure at 50 °C in the aerosol dispenser must not exceed the values provided for in the following table, depending upon the content of gases in the aerosol dispenser.

Content of gases	Pressure at 50 °C
Liquefied gas or mixture of gases having a flammable range with air at 20 °C and a standard pressure of 1,013 bar	12 bar
Liquefied gas or mixture of gases not having a flammable range with air at 20 °C and a standard pressure of 1,013 bar	13,2 bar
Compressed gases or gases dissolved under pressure not having a flammable range with air at 20 °C and a standard pressure of 1,013 bar	15 bar

4. SPECIAL PROVISIONS FOR GLASS AEROSOL DISPENSERS

4.1-Plastic coated or permanently protected containers

Containers of this type may be used for filling with compressed, liquefied or dissolved gas.

4.1.1-Capacity

The total capacity of such containers may not exceed 220 ml.

4.1.2-Coating

The coating must be a protective envelope of plastic or other suitable material, intended to prevent the risk of flying particles of glass if the container is accidentally broken, and must be so designed that there are no flying particles of glass if the filled aerosol dispenser, brought to a temperature of 20° C, is dropped from a height of 1,8 m onto a concrete floor.

4.1.3- Test pressure of the container

a) Containers used for filling with compressed or dissolved gas must resist a test pressure equal to at least 12 bars.

b) Containers used for filling with liquefied gas must resist a test pressure equal to at least 10 bars.

4.1.4- Filling

a) Aerosol dispensers filled with compressed gas shall not be required to withstand a pressure of more than 9 bars at 50° C.

b) Aerosol dispensers filled with dissolved gas shall not be required to withstand a pressure of more than 8 bars at 50° C.

c) Aerosol dispensers containing liquefied gas or mixtures of liquefied gas shall not be required to withstand, at 20° C, pressures higher than those shown in the following table.

Total capacity (V) (ml)	Percentage by weight of liquefied gas in the total mixture		
	% 20	% 50	% 80
$50 \leq V < 80$	3,5 bar	2,8 bar	2,5 bar
$80 \leq V < 160$	3,2 bar	2,5 bar	2,2 bar
$160 \leq V \leq 200$	2,8 bar	2,1 bar	1,8 bar

This table shows the pressure limits permitted at 20° C in relation to the percentage of gas. Pressure limits for percentages of gas not shown in the table shall be extrapolated from it.

4.2- Unprotected glass containers

Aerosol dispensers using unprotected glass containers shall be filled exclusively with liquefied or dissolved gases.

4.2.1- Capacity

The total capacity of these containers may not exceed 150 ml.

4.2.2- Test pressure of the container

The test pressure of the container must be equal to at least 12 bars.

4.2.3- Filling

a) Aerosol dispensers filled with dissolved gas shall not be required to withstand a pressure of more than 8 bars at 50° C.

b) Aerosol dispensers containing liquefied gas shall not be required to withstand, at 20° C, pressures in excess of those shown in the following table.

Total Capacity (V) (mℓ)	Percentage by weight of liquefied gas in the total mixture		
	% 20	% 50	% 80
$50 \leq V < 70$	1,5 bar	1,5 bar	1,25 bar
$70 \leq V \leq 150$	1,5 bar	1,5 bar	1 bar

This table shows the pressure limits permitted at 20° C in relation to the percentage of liquefied gas. Pressure limits for percentages of gas not shown in the table shall be extrapolated from it.

5- SPECIAL PROVISIONS APPLYING TO PLASTIC AEROSOL DISPENSERS

5.1- Plastic aerosol dispensers which may splinter on bursting shall be treated in the same way as unprotected glass aerosol dispensers.

5.2- Plastic aerosol dispensers which cannot splinter on bursting shall be treated in the same way as glass aerosol dispensers with a protective coating.

6- TESTS

6.1- Test requirements to be guaranteed by the person responsible for marketing

6.1.1- Hydraulic test on empty containers

6.1.1.1- Metal, glass or plastic aerosol dispensers must be able to withstand a hydraulic pressure test as laid down in 3.1.1, 4.1.3 and 4.2.2.

6.1.1.2- Metal containers showing asymmetrical or major distortions or other similar faults shall be rejected. A slight symmetrical distortion of the base or one affecting the profile of the upper casing shall be allowed provided that the container passes the bursting test.

6.1.2- Bursting test for empty metal containers

The person responsible for marketing must ensure that the bursting pressure of containers is at least 20 % higher than the test pressure laid down.

6.1.3- Dropping test for protected glass containers

The manufacturer must ensure that the containers satisfy the test requirements laid down in 4.1.2.

6.1.4- Final inspection of filled aerosol dispensers

6.1.4.1- Aerosol dispensers shall be subject to one of the following final test methods.

a) Hot water bath test

Each filled aerosol dispenser shall be immersed in a hot water bath.

1) The temperature of the water bath and the duration of the test shall be such that the internal pressure reaches that which would be exerted by its contents at a uniform temperature of 50 °C.

2) Any aerosol dispenser showing visible permanent distortion or a leak must be rejected.

b) Hot final test methods

Other methods for heating the contents of aerosol dispensers may be used if they guarantee that the pressure and temperature in each filled aerosol dispenser reach the values required for the hot water bath test and distortions and leaks are detected with same precision as in the case of the hot water bath test.

c) Cold final test methods

An alternative cold final test method may be used if it is in accordance with the provisions of an alternative method to the hot water bath test for aerosol dispensers specified in ADR.

6.1.4.2- For aerosol dispensers the contents of which undergo a physical or chemical transformation changing their pressure characteristics after filling and before first use, cold final test methods should be applied.

6.1.4.3- In case of test methods according to points 6.1.4.1(b) and 6.1.4.1(c):

a) The test method must be approved by a competent authority.

b) The person responsible for the marketing of aerosol dispensers must submit an application for approval to a competent authority. The application must be accompanied by the technical file describing the method.

c) The person responsible for the marketing of aerosol dispensers must, for surveillance purposes, keep the approval of the competent authority, the technical file describing the method and, if applicable, control reports readily available at the address specified on the label in accordance with this Regulation.

ç) The technical file must be established in an official Community language or a certified copy thereof must be available.

d) 'competent authority' means the authority designated in ADR.

6.2- Examples of inspection tests which may be carried out

6.2.1- Test on unfilled containers

The test pressure shall be applied for 25 seconds on five containers selected at random from a homogeneous batch of 2500 unfilled containers, i.e. manufactured from the same materials by the same continuous batch manufacturing process, or from a batch constituting one hour's production. If any one of these containers does not pass the test, ten additional containers shall be drawn at random from the same batch and put through the same test. If any one of these aerosol containers does not pass the test, the whole batch shall be unsuitable for use.

6.2.2- Tests on filled aerosol dispensers

Air and water-tightness inspection tests shall be carried out by immersing a representative number of filled aerosol dispensers in a bath of water. The temperature of the bath and the period of immersion must be such as to enable the contents of the aerosol dispenser to attain a uniform temperature of 50° C during the time required to ensure that there is no bursting or rupture. Any batch of aerosol dispensers which does not pass these tests must be considered unsuitable for use.

6.3- Tests on the flammability of aerosols

6.3.1- Ignition distance test for spray aerosols

6.3.1.1- Introduction

6.3.1.1.1- This test standard describes the method to determine the ignition distance of an aerosol spray in order to assess the associated flame risk. The aerosol is sprayed in the direction of an ignition source at intervals of 15 cm to observe if ignition and sustained combustion of the spray takes place. Ignition and sustained combustion is defined as when a stable flame is maintained for at least five seconds. The ignition source is defined as a gas burner with a blue, non-luminous flame 4-5 cm in height.

6.3.1.1.2- This test is applicable to aerosol products with a spray distance of 15 cm or more. Aerosol products with a spray distance of less than 15 cm such as dispensing foams, mousses, gels and pastes or fitted with a metering valve, are excluded from this test. Aerosol products that dispense foams, mousses, gels or pastes are subject to testing under the aerosol foam flammability test.

6.3.1.2- Apparatus and material

6.3.1.2.1- The following apparatus is required:

Water bath maintained at 20 °C	accurate to ± 1 °C
Calibrated laboratory scales (balance)	accurate to $\pm 0,1$ g
Chronometer (stopwatch)	accurate to $\pm 0,2$ s
Graduated scale, support and clamp	graduations in cm
Gas burner with support and clamp	
Thermometer	accurate to ± 1 °C
Hygrometer	accurate to ± 5 %
Pressure gauge	accurate to $\pm 0,1$ bar

6.3.1.3- Procedure

6.3.1.3.1- General requirements

6.3.1.3.1.1- Before testing, each aerosol dispenser shall be conditioned and then primed by discharging for approximately one second. The purpose of this action is to remove non-homogeneous material from the diptube.

6.3.1.3.1.2- The instructions of use shall be strictly followed, including whether the dispenser is intended to be used in the upright or inverted position. When shaking is required, shake immediately before testing.

6.3.1.3.1.3- The test shall be carried out in a draught-free environment capable of ventilation, with the temperature controlled at $20\text{ }^{\circ}\text{C} \pm 5\text{ }^{\circ}\text{C}$ and relative humidity in the range 30-80 %.

6.3.1.3.1.4- Each aerosol dispenser is to be tested:

a) when full according to the complete procedure, with the gas burner in the range of 15-90 cm distance from the actuator of the aerosol can;

b) when 10-12 % full nominal (% by mass) only one test, either at 15 cm distance from the actuator when the spray from a full can did not ignite at all, or at the flame ignition distance of the spray of a full can plus 15 cm.

6.3.1.3.1.5- During the test, the can shall be positioned as indicated by label instructions. The ignition source shall be positioned accordingly.

6.3.1.3.1.6- The following procedure requires testing the spray at intervals of 15 cm between the burner flame and the aerosol actuator, in the range of 15-90 cm. It is efficient to start at 60 cm distance between burner flame and aerosol actuator. The distance between burner flame and aerosol actuator shall be increased by 15 cm in the case of an ignition of the spray at 60 cm distance. The distance shall be decreased by 15 cm in the case of no ignition at 60 cm distance between burner flame and aerosol actuator. The aim of the procedure is to determine the maximum distance between aerosol actuator and burner flame that leads to sustained combustion of the spray or to determine that ignition could not be obtained at 15 cm distance between the burner flame and the aerosol's actuator.

6.3.1.3.2- Test procedure

a) A minimum of 3 full aerosol dispensers per product shall be conditioned to $20\text{ }^{\circ}\text{C} \pm 1\text{ }^{\circ}\text{C}$ with at least 95 % of the dispenser immersed in the water for at least 30 min before each test (if the aerosol is fully immersed, 30 min conditioning is sufficient);

b) Comply with general requirements. Record the temperature and relative humidity of the environment;

c) Weigh an aerosol dispenser and note its mass;

c) Determine the internal pressure and initial discharge rate at $20\text{ }^{\circ}\text{C} \pm 1\text{ }^{\circ}\text{C}$ (to eliminate faulty or partly filled aerosol dispensers);

d) Support the gas burner on a flat horizontal surface or fix the burner to a support by means of a clamp;

e) Ignite the gas burner; the flame shall be non-luminous and approximately 4-5 cm high;

- f) Place the actuator's exit orifice at the required distance from the flame. The aerosol shall be tested in the position it is designed to be used, e.g. upright or inverted;
- g) Level the actuator's orifice and burner flame, ensuring that the orifice is properly directed towards and aligned with the flame (see Figure 6.3.1.1). The spray shall be expelled through the top half of the flame;

Figure 6.3.1.1

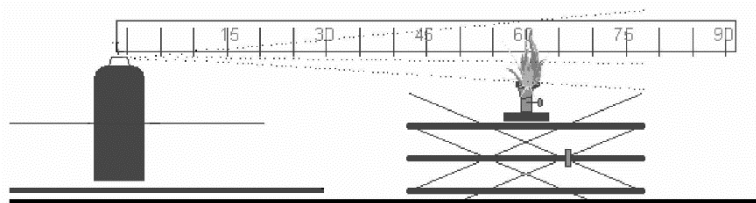

- ğ) Comply with the general requirements regarding shaking of the dispenser;
- h) Actuate the valve of the aerosol dispenser, to discharge its contents for five seconds, unless ignition occurs. If ignition occurs, continue discharging and time the duration of the flame for five seconds, from the start of ignition;
- i) Note the ignition results for the distance between the gas burner and the aerosol dispenser in the table provided;
- i) If no ignition occurs during step (h), the aerosol shall be tested in alternative orientations, e.g. inverted for upright use products, to check if ignition is obtained;
- j) Repeat steps (f) to (i) twice more (a total of 3) for the same can at the same distance between the gas burner and the aerosol actuator;
- k) Repeat the test procedure for another two aerosol cans of the same product at the same distance between gas burner and aerosol actuator;
- l) Repeat steps (f) to (k) of the test procedure at a distance between 15 and 90 cm between the actuator of the aerosol can and the burner flame depending on the outcome of each test (see also 6.3.1.3.1.4 and 6.3.1.3.1.5);
- m) If no ignition occurs at 15 cm, the procedure is finished for initially full cans. The procedure is also finished when ignition and sustained combustion is obtained at a distance of 90 cm. If ignition could not be obtained at 15 cm distance, record that ignition did not occur. The maximum distance between burner flame and the aerosol's actuator for which an ignition and sustained combustion was observed is noted as the 'ignition distance', in all other circumstances;
- n) One test shall also be conducted on three cans of 10-12 % nominal fill level. These cans shall be tested at a distance between the aerosol's actuator and the burner flame of the 'flame ignition distance of full cans + 15 cm';
- o) Discharge an aerosol can to a 10-12 % nominal fill level (by mass) in bursts of 30 seconds maximum. Observe a 300 seconds minimum time period between bursts. During this interim period dispensers shall be placed in the water bath for conditioning;
- ö) Repeat steps (f) to (k) for 10-12 % nominal fill aerosol cans, omitting steps (i) and (j). This test shall only be performed with the aerosol in one position, e.g. upright or inverted, corresponding with that which produced the ignition (if any) for filled cans;
- p) Record all results in the Table 6.3.1.1 as shown below.

Observations — including can position				
---	--	--	--	--

6.3.2- Enclosed space ignition test

6.3.2.1- Introduction

This test standard describes the method to assess the flammability of products emerging from aerosol dispensers due to their propensity to ignite in an enclosed or confined space. The contents of an aerosol dispenser are sprayed into a cylindrical test vessel containing a burning candle. If an observable ignition occurs, the elapsed time and amount discharged is noted.

6.3.2.2- Apparatus and material

6.3.2.2.1- The following apparatus is required:

Chronometer (stopwatch)	accurate to $\pm 0,2$ s
Water bath maintained at 20 °C	accurate to ± 1 °C
Calibrated laboratory scales (balance)	accurate to $\pm 0,1$ g
Thermometer	accurate to ± 1 °C
Hygrometer	accurate to ± 5 %
Pressure gauge	accurate to $\pm 0,1$ bar
Cylindrical test vessel	as detailed below

6.3.2.2.2- Preparation of test apparatus

6.3.2.2.2.1- A cylindrical vessel approximately 200 dm³ volume, approximately 600 mm in diameter and approximately 720 mm long and open at one end shall be modified as follows:

a) A closure system consisting of a hinged cover shall be matched to the open end of the receptacle; or

b) A plastic film 0,01 to 0,02 mm thick may be used as a closure system. If the test is carried out with a plastic film this must be used as described below: Stretch the film over the open end of the drum and hold it in place with an elastic band. The strength of the band shall be such that when placed around the drum resting on its side, it stretches by only 25 mm when a mass of 0,45 kg is attached to its lowest point. Cut a 25 mm slit in the film, starting 50 mm from the edge of the drum. Ensure that the film is taut;

c) At the other end of the drum drill a 50 mm diameter hole 100 mm from the edge in such a way that the orifice is uppermost when the receptacle is laid down and ready for the test (Figure 6.3.2.1.);

Figure 6.3.2.1

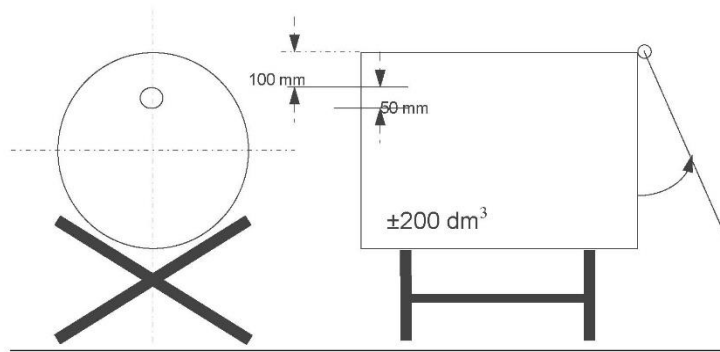

ç) On a 200×200 mm metal support place a paraffin wax candle 20 to 40 mm in diameter and 100 mm high. The candle shall be replaced when having a height of less than 80 mm. The candle's flame is protected from the action of the spray by a 150 mm wide, 200 mm high deflector. This includes the plane inclined at 45° produced 150 mm from the base of the deflector (Figure 6.3.2.2.);

Figure 6.3.2.2

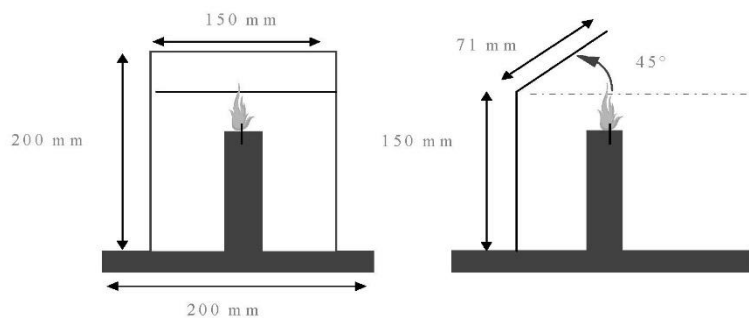

d) The candle placed on the metal support shall be positioned midway between the two ends of the drum (Figure 6.3.2.3);

Figure 6.3.2.3

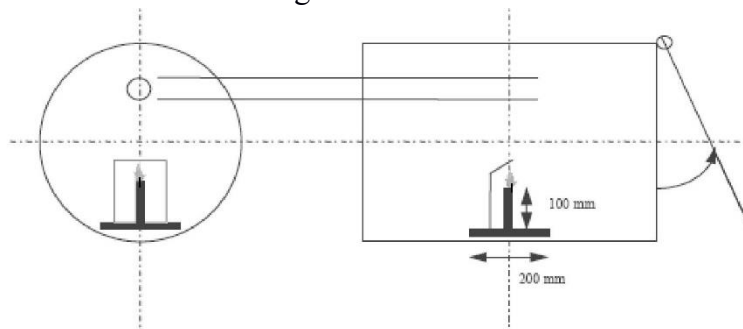

e) The drum is laid on the ground or on a support at a spot where the temperature is between 15°C and 25°C . The product to be tested will be sprayed within the drum of roughly 200 dm^3 in which there will be a source of ignition.

6.3.2.2.2- Usually, the product leaves the aerosol can at an angle of 90° relevant to the vertical axis of the can. The layout and procedure described refers to this kind of aerosol product. In the case of unusually operating aerosols (e.g. vertical-spray aerosol dispensers) it will be necessary to record changes to equipment and procedures in accordance with good laboratory practice, such as ISO/IEC 17025:1999 General requirements for the competence of testing and calibration laboratories.

6.3.2.3- Procedure

6.3.2.3.1- General requirements

6.3.2.3.1.1- Before testing, each aerosol dispenser shall be conditioned and then primed by discharging for approximately 1 second. The purpose of this action is to remove non-homogeneous material from the diptube.

6.3.2.3.1.2- The instructions of use shall be strictly followed, including whether the dispenser is intended to be used in the upright or inverted position. When shaking is required, shake immediately before testing.

6.3.2.3.1.3- The tests shall be carried out in a draught-free environment capable of ventilation, with the temperature controlled at $20\text{ °C} \pm 5\text{ °C}$ and relative humidity in the range 30-80 %.

6.3.2.3.2- Test procedure

- a) A minimum of 3 full aerosol dispensers per product shall be conditioned to $20\text{ °C} \pm 1\text{ °C}$ in a water bath with at least 95 % of the dispenser immersed in the water for at least 30 min (if the aerosol is fully immersed, 30 min conditioning is sufficient);
- b) Measure or calculate the actual volume of the drum in dm^3 ;
- c) Comply with general requirements. Record the temperature and relative humidity of the environment;
- ç) Determine the internal pressure and initial discharge rate at $20\text{ °C} \pm 1\text{ °C}$ (to eliminate faulty or partly filled aerosol dispensers);
- d) Weigh one of the aerosol dispensers and note its mass;
- e) Light the candle and apply the closure system (cover or plastic film);
- f) Place the aerosol dispenser actuator orifice 35 mm or closer for a wide spray product, from the centre of the entrance hole in the drum. Start the chronometer (stopwatch) and following the instructions for use of the product; direct the spray towards the centre of the opposite extremity (cover or plastic film). The aerosol shall be tested in the position it is designed to be used, e.g. upright or inverted;
- g) Spray until ignition occurs. Stop the chronometer and note the time elapsed. Re-weigh the aerosol dispenser and note its mass;
- ğ) Ventilate and clean the drum removing any residue likely to affect subsequent tests. Allow the drum to cool if necessary;
- h) Repeat the test procedure steps (ç) to (ğ) for another two aerosol dispensers of the same product (three in total, note: each dispenser is only tested once);

6.3.2.4- Method of assessing results

6.3.2.4.1- A test report containing the following information shall be drawn up:

- a) The product tested and its references;
- b) The internal pressure and discharge rate of the aerosol dispenser;
- c) The temperature and relative air humidity of the room;
- ç) For each test, the discharge time needed (s) to achieve ignition (if the product does not ignite, state this);
- d) The mass of the product sprayed during each test (in g);
- e) The actual volume of the drum (in dm³).

6.3.2.4.2- The time equivalent (t_{eq}) needed to achieve ignition in one cubic metre can be calculated as follows:

$$t_{eq} = \frac{1000 \times \text{discharge time (s)}}{\text{Actual volume of drum (dm}^3\text{)}}$$

6.3.2.4.3- The deflagration density (D_{def}) needed to achieve ignition during the test may also be calculated as follows:

$$D_{def} = \frac{1000 \times \text{Amount of product dispensed (g)}}{\text{Actual volume of drum (dm}^3\text{)}}$$

6.3.3- Aerosol foam flammability test

6.3.3.1- Introduction

6.3.3.1.1- This test standard describes the method to determine the flammability of an aerosol spray emitted in the form of a foam, mousse, gel or paste. An aerosol, which emits a foam, mousse, gel or paste is sprayed (approximately 5 g) on a watchglass and an ignition source (candle, wax taper, match or lighter) is placed at the base of the watchglass to observe if ignition and sustained combustion of the foam, mousse, gel or paste occurs. Ignition is defined as a stable flame maintained for at least two seconds and a minimum 4 cm in height.

6.3.3.2- Apparatus and material

6.3.3.2.1- The following apparatus is required:

Graduated scale, support and clamp	gradations in cm
Fire-resistant watchglass roughly 150 mm in diameter	
Chronometer (stopwatch)	accurate to $\pm 0,2$ s

Candle, wax taper, match or lighter	
Calibrated laboratory scales (balance)	accurate to $\pm 0,1$ g
Water bath maintained at 20 °C	accurate to ± 1 °C
Thermometer	accurate to ± 1 °C
Hygrometer	accurate to ± 5 %
Pressure gauge	accurate to $\pm 0,1$ bar

6.3.3.2.2- The watchglass is placed on a fire-resistant surface within a draught-free area that may be ventilated after each test. The graduated scale is positioned exactly behind the watchglass and held vertically by means of a support and clamp.

6.3.3.2.3- The scale is positioned in such a way that its origin is on a level with the watchglass base in a horizontal plane.

6.3.3.3-Procedure

6.3.3.3.1- General requirements

6.3.3.3.1.1- Before testing, each aerosol dispenser shall be conditioned and then primed by discharging for approximately 1 second. The purpose of this action is to remove non-homogeneous material from the diptube.

6.3.3.3.1.2- The instructions of use shall be strictly followed, including whether the dispenser is intended to be used in the upright or inverted position. When shaking is required, shake immediately before testing.

6.3.3.3.1.3- The tests shall be carried out in a draught-free environment capable of ventilation, with the temperature controlled at $20\text{ °C} \pm 5\text{ °C}$ and relative humidity in the range of 30-80 %.

6.3.3.3.2- Test procedure

a) A minimum of four full aerosol dispensers per product shall be conditioned to $20\text{ °C} \pm 1\text{ °C}$ with at least 95 % of the dispenser immersed in the water for at least 30 min before each test (if the aerosol is fully immersed, 30 min conditioning is sufficient);

b) Comply with general requirements. Record the temperature and relative humidity of the environment;

c) Determine the internal pressure at $20\text{ °C} \pm 1\text{ °C}$ (to eliminate faulty or partly filled aerosol dispensers);

ç) Measure the discharge or flow rate of the aerosol product to be examined, so that the amount of test product dispensed can be more accurately gauged;

d) Weigh one of the aerosol dispensers and note its mass;

e) On the basis of the measured discharge or flow rate and following the manufacturer's instructions, release approximately 5 g of the product onto the centre of the clean watchglass with the aim of producing a mound no higher than 25 mm;

f) Within five seconds of completion of discharge, apply the source of ignition to the edge of the sample at its base and at the same time start the chronometer (stopwatch). If necessary, the ignition source shall be removed from the edge of the sample after approximately two seconds, in order to clearly observe if ignition has occurred. If no ignition of the sample is apparent, the ignition source shall be reapplied to the edge of the sample;

g) If ignition occurs note the following points:

- 1) The maximum height of the flame in cm above the base of the watchglass;
- 2) The flame duration in s;
- 3) Dry and re-weigh the aerosol dispenser and calculate the mass of the released product;

ğ) Ventilate the test area immediately after each test;

h) If ignition is not obtained and the released product remains in the form of a foam or paste throughout its period of use, steps (d) to (ğ) shall be repeated. Allow the product to stand for 30 sec, 1 min, 2 min or 4 min before applying the ignition source;

i) Repeat the test procedure steps (d) to (h) twice more (a total of 3) for the same can;

i) Repeat the test procedure steps (d) to (i) for another two aerosol cans (3 cans in total) of the same product.

6.3.3.4- Method of assessing results

6.3.3.4.1- A test report containing the following information shall be drawn up:

- a) whether the product ignites;
- b) maximum flame height in cm;
- c) duration of flame in s;
- ç) the mass of the product tested.